

# Rapid Prototyping for Robotics

*Imme Ebert-Uphoff, Clement M. Gosselin, David W. Rosen & Thierry Laliberte*

## 1. Introduction

The design of robotic mechanisms is a complex process involving geometric, kinematic, dynamic, tolerance and stress analyses. In the design of a real system, the construction of a physical prototype is often considered. Indeed, a physical prototype helps the designer to identify the fundamental characteristics and the potential pitfalls of the proposed architecture. However, the design and fabrication of a prototype using traditional techniques is rather long, tedious and costly. In this context, the availability of rapid prototyping machines can be exploited in order to allow designers of robotic mechanisms or other systems to build prototypes rapidly and at a low cost.

This chapter summarizes the research experience of two research groups, one at Université Laval, the other at Georgia Tech, concerning the rapid prototyping of mechanisms. The two groups employed two different types of RP technology, Fused Deposition Modeling (FDM) and Stereolithography (SL), respectively, and the use of both is described in this chapter.

The two types of Rapid Prototyping technologies considered here, FDM and SL, are both based on the principle of Additive Fabrication, i.e. parts are built by adding material to the whole, as opposed to subtracting material from the whole (as is done in traditional machining processes). FDM and SL both build three-dimensional parts from a CAD model by building one layer after the other, which facilitates the construction of parts with any desired internal and external geometry in a fraction of the time and cost necessary to build them using a conventional process (Ashley, 1995). Additive Fabrication therefore provides several advantages for the quick and efficient construction of mechanical prototypes:

- Quick turn-around time, thus facilitating many design iterations;
- No limits on part complexity, as parts with complex geometry can be built just as quickly and cheaply as parts with simple geometry;
- Since most components are “self-made”, there are no issues of components being available only in certain sizes from a manufacturer;
- Since the designer has access to the interior of the part during the build process, Additive Fabrication provides novel design possibilities (Binnard, 1999). These capabilities can be exploited to yield short-cuts that eliminate the need for fasteners and the need for assembly of the prototypes.

Depending on the stage of development of the system to be prototyped, different strategies may be employed:

- (A) At an early stage of experimentation the main goal is to quickly achieve a prototype that provides the basic functionality of the desired system. Implementation details

are usually irrelevant at this stage, allowing for use of RP-specific short-cuts in the implementation to yield faster turn-around time.

- (B) At the final design stages it is often desired that all parts of the prototype resemble the mechanism to be manufactured in as much detail as possible to test all aspects of the design.

## **1.1 Components of Robotic Mechanisms and Their Fabrication & Integration in Rapid Prototyping**

Prototypes of robotic mechanisms require a variety of different components, which, in the context of this chapter, are categorized in the following three groups:

1. Rigid links;
2. Joints between the rigid links that enable motion;
3. External components that are required for the prototype, but that are not fabricated using Rapid Prototyping. Examples: actuators, sensors, circuits, etc.

This chapter discusses how RP can be used to generate a prototype of a mechanism that contains all of these components in an efficient manner. Different approaches exist for the fabrication and integration of the components as outlined below:

1. Rigid Links: Rigid links of any shape are easy to fabricate in Rapid Prototyping. Since the construction of rigid parts is the classic use of Rapid Prototyping, much research has been reported in this area and this topic is not further discussed in this chapter.
2. Joints Between Rigid Links: Mechanical joints can be fabricated as conventional (kinematic) joints or as compliant joints. Furthermore, conventional joints can be built in several parts, requiring assembly afterwards, or in a single step. All of these possibilities are discussed in this chapter.
3. Integration of external components (actuators, sensors, etc.): These components can be attached to the prototype through screws and fasteners, in order to mimic the design of the the final mechanism to be manufactured in as much detail as possible. As an alternative approach, one can seek to add actuators and sensors at the interior of parts by inserting them while the part is being built. This may eliminate the assembly process, the design of fasteners, etc., and thus speed up the prototyping process considerably at an early stage. Both of these approaches are considered in this chapter.

## **1.2 Organization of this Chapter**

The remainder of this chapter is organized as follows: Section 2. reviews different types of RP technologies with emphasis on FDM and SL technologies. Section 3. reviews related research on the use of RP for automation and robotics.

Section 4. describes the use of FDM technology to build mechanical prototypes of mechanisms. A database of joint models, gears and fasteners, suitable for fabrication in FDM machines is introduced that provides the building blocks for the prototyping of mechanisms. All joints are of conventional type (with assembly) and external components are attached in the traditional way, mimicking the implementation of the final mechanism to be manufactured in as much detail as possible. Examples of several passive and actuated mechanisms are provided.

Section 5. discusses the fabrication of joints using SL technology. Conventional joints are discussed first and it is shown that the joint models developed in Section 4. can easily be

adopted for joint fabrication using SL technology. Then the fabrication of non-assembly conventional joints and non-assembly compliant joints using SL machines is discussed. Section 6. explores the insertion of external components at the inside of parts during the build process. This research is more exploratory, but may ultimately lead to quicker turn-around times for prototypes in many applications, by eliminating the need for the design of fasteners and the assembly process at early stages of design. Section 7. finally presents conclusions.

## **2. Rapid Prototyping Technologies**

A wide variety of rapid prototyping technologies exists (for an excellent overview, see Kai & Fai (1997)) and many of them can be used for applications in Automation and Robotics (Wohlers, 1993). The principal idea underlying rapid prototyping technologies is that parts and devices are fabricated using a layer-based, additive process. A wide variety of material deposition methods, processing methods, and materials have been explored. For example, in the Selective Laser Sintering (SLS) process, a laser sinters, or melts, polymer powder particles together to form a part cross-section, while in Stereolithography a laser induces a chemical gelling reaction in a liquid photopolymer to fabricate the cross-section. In Fused-Deposition Modeling, a heated extrusion head extrudes polymer filament to trace out a part cross-section. These, and additional technologies, have been used in many applications other than making plastic prototypes, including medical visualization models, patterns for investment casting, molds for injection molding, and even some production uses (Jacobs, 1996).

Two technologies, FDM and SL, are used throughout this chapter to exemplify the capabilities of RP technology, with SL currently being the most widely used method of Rapid Prototyping world-wide. Parts fabricated by SL and FDM are typically of polymer material and ABS polymer, respectively, which may not be rigid enough for some applications. However, most of the discussion is not limited to those two technologies. If desired, other RP technologies, such as Selective Laser Sintering or Laser Engineered Net Shaping (LENS), can be employed to obtain metal parts with improved material properties.

### **2.1 Fused Deposition Modeling**

One of the machines used here is a FDM 2000 rapid prototyping machine from Stratasys Inc., with the Fused Deposition Modeling technology (FDM). In the FDM technology, a thin thread of fused material is deposited layer by layer. The material usually used is ABS polymer. A supporting material is necessary where a new slice does not have any support from previous slices. Once the whole part is made, the supporting material is removed and some finishing is done if necessary. The main advantages of this specific technology are simplicity of use and relatively low cost. There are some limitations regarding the dimensional accuracy and the surface finish. Since the section of the part already built is not refused when the new material is deposited, the bounding between the layers and between the threads is not complete. Therefore, the parts are anisotropic and the material is weaker in the direction of fabrication, which corresponds to the direction of the slicing. Each rapid prototyping technology has its own software. This software is able to understand a standard type of file named STL (Wohler, 1992). Most of the CAD packages are able to create an STL file of a part. In this work, the STL files are generated from Pro-Engineer. From this STL file, the software processes the model of the part into the

appropriate format. For the FDM technology, the part is first moved in an appropriate orientation. Then, the part is sliced in horizontal layers. The necessary support material is then created to hold the sections of the part which do not lie on lower layers. Finally, the roads—the paths where the threads of material are deposited—are created for each slice. This process can be performed automatically. However, depending on the desired properties of the part, parameters of the roads (size, spacing and pattern) can be modified manually. In order to clarify the process, an example is presented in Figure 1 (a), (b), (c) and (d).

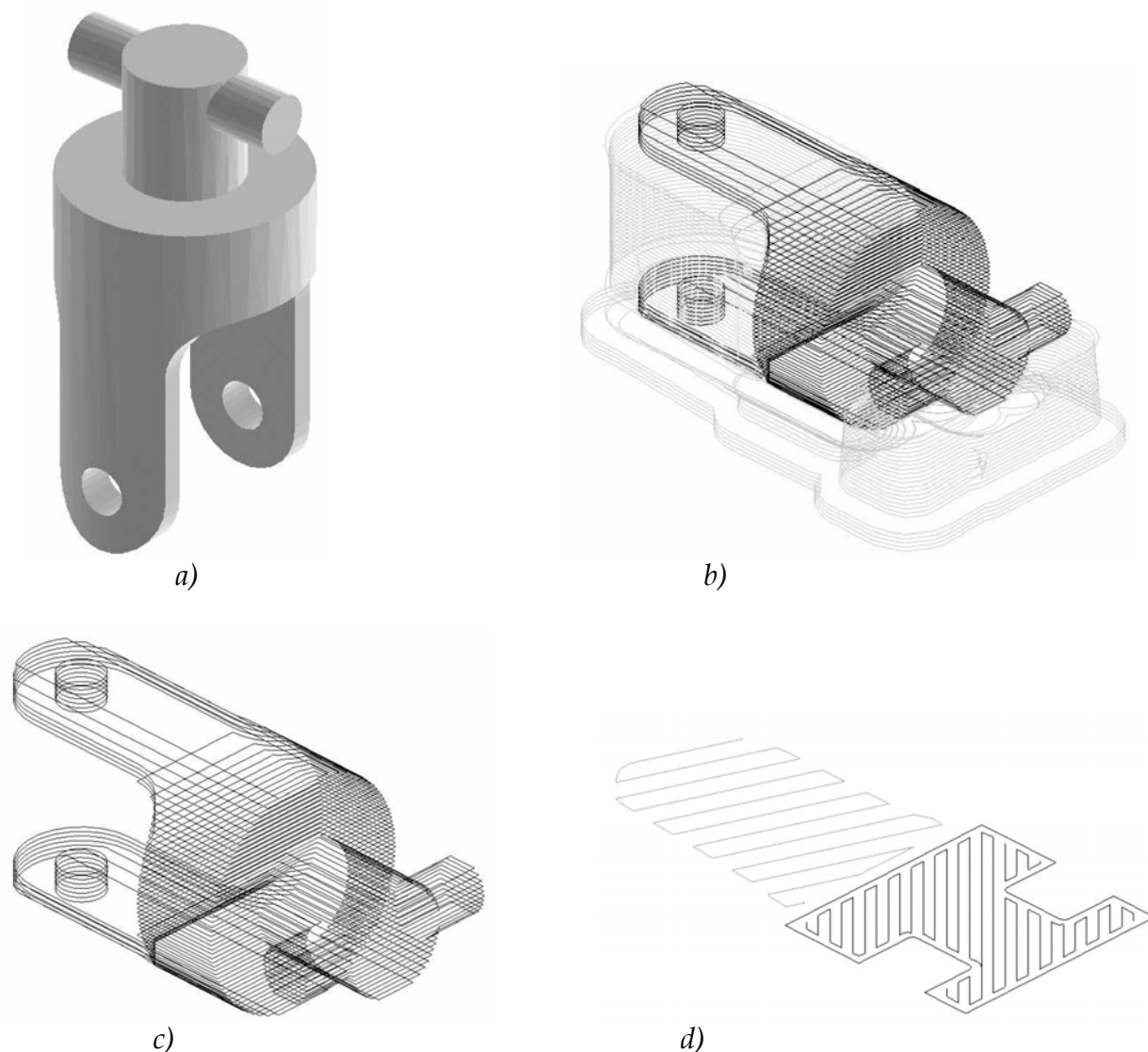

Figure 1. Example of the software process: (a) Part in STL format in its original orientation. (b) Part properly oriented and sliced. (c) Support material added to the sliced part. (d) Roads in one of the slices. Note that the roads of the support material include gaps between them for easy removal

## 2.2 Background on Stereolithography

Stereolithography (SL) is currently the most widely used RP method and it is used as the second example throughout the chapter. SL is a method of rapidly prototyping parts by using a photo-polymer resin cured by an ultraviolet laser layer by layer. This allows the user to go quickly from a CAD file to a physical three-dimensional manifestation of the part.

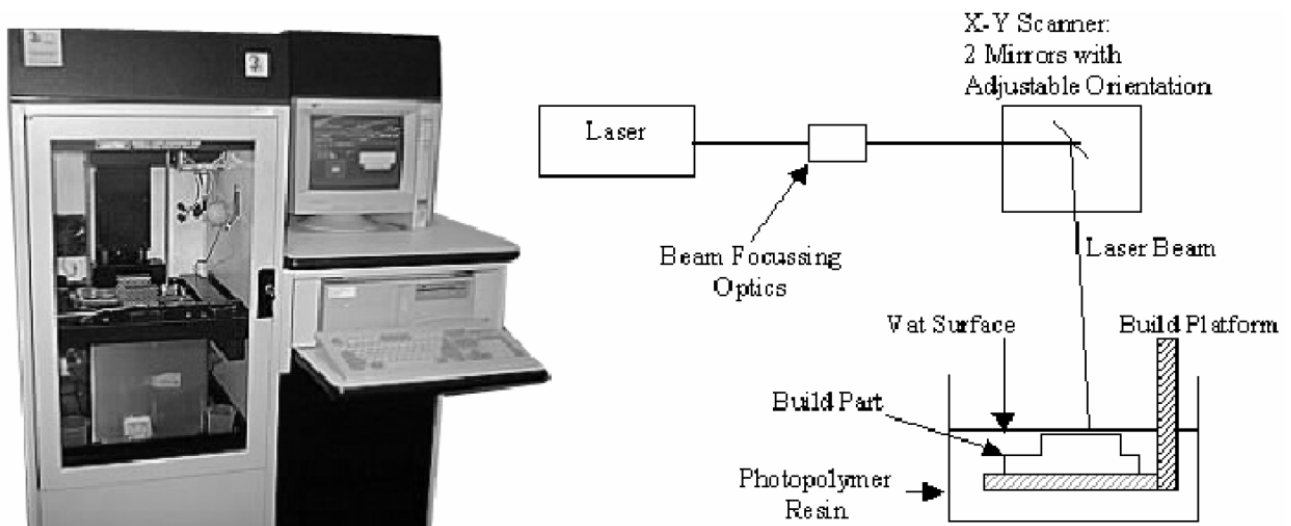

Figure 2. Stereolithography Apparatus (SLA 250) from 3D Systems with a Schematic of the Process

A photograph of a stereolithography apparatus (SLA) along with a schematic of the SL process is shown in Figure 2. A typical SLA consists of an ultraviolet laser, beam focusing optics, two galvanometers that each consist of a mirror oriented by a small motor, a vat of photo-polymer resin, and a build platform that raises and lowers the build part.

A typical build process is completed in the following manner. A laser generates a laser beam that is conditioned and refocused using beam focusing optics. The beam is then reflected by two mirrors that can each rotate about a single fixed axis. Using these two mirrors the beam can be directed to any point (x,y) on the vat surface. The resin at the surface of the vat is cured along the trajectory created by the laser. Thus, by scanning the shape of the part's cross section, one layer of the part is constructed.

The platform holding the part is then lowered by one layer (generally 0.05 - 0.2 mm) into the vat and the process continues with the next layer. Before the next layer is built, a recoating mechanism, in form of a blade, slides over the surface to distribute the liquid resin evenly on the surface of the part to be built.

Section 6.2 describes the construction of a functional model of the SLA 250 shown in Figure 2, including all mechanical and optical components, built in an SLA 250 machine.

### 2.3 Glossary of Terms

For the convenience of the reader the following summarizes the acronyms used throughout this chapter:

RP Rapid Prototyping - a method of fabricating a physical three-dimensional manifestation of a part from the CAD file of the part;

AF Additive Fabrication - is defined as building products in a process of adding material to the whole, as opposed to subtracting material (as is traditionally done). All of the following are examples of Additive Fabrication.

SL Stereolithography - is a layered manufacturing technique that builds 3D objects layer by layer using an ultraviolet laser and photosensitive polymer resin.

SLA Stereolithography Apparatus - is the acronym for a Stereolithography machine.

SLS Selective Laser Sintering - is a layered manufacturing technique that builds 3D objects layer by layer using a heat generating CO<sub>2</sub> laser and powders made of materials including polycarbonate, nylon, and metal.

FDM Fused Deposition Modeling – is a layered manufacturing technique that builds 3D objects layer by layer using two nozzles which place ABS or polyamide (as the building material) and modified ABS (as the support material).

Note that British units of measurement are used frequently in this chapter, since these units are used with RP machines. Metric equivalents follow in parentheses.

### **3. Related Research on the Use of RP for Automation and Robotics**

The traditional use of Rapid Prototyping is the fabrication of rigid parts. However, in recent years several research groups have discovered the potential of producing (robotic) mechanisms using RP, including Laliberté et al. (1999), Alam et al. (1999), Diez (2001), Rajagopalan & Cutkosky (1998, 1999) and Binnard (1999).

The fabrication of joints is a crucial first step for the fabrication of mechanisms using RP. Laliberté et al. (1999, 2000) present the generic design of joints using the FDM process. Joints for SL and Selective Laser Sintering processes are presented by Alam et al. (1999) and Won et al. (2000). Kataria (2000) discusses the fabrication and required clearances for various non-assembly prismatic joints and revolute joints for both SLA-250 and SLA-3500 machines. Diez (2001) discusses the fabrication of a very different type of joint for SL technology: compliant joints are considered, i.e. joints consisting of a single part that can be bent in some fashion.

Joints presented in Laliberté et al. (1999, 2000) require assembly after fabrication, while the joints presented in Alam et al. (1999); Won et al. (2000); Kataria (2000); Diez (2001) are fabricated in already assembled form. Rajagopalan & Cutkosky (1998) present a framework for the analysis of the effect of geometry gaps and clearances on mechanism assemblies in RP, which applies to assembly and non-assembly joint types.

Numerous complex passive and actuated mechanisms using the above joint types were successfully fabricated using RP, including a robotic hand (Won et al., 2000) and several parallel platform mechanisms (Laliberté et al., 2000). Additional examples are provided in this chapter.

Lipson & Pollack (2000) investigated the automatic design and manufacture of what they call “robotic lifeforms”, where manufacture was by FDM. They programmed software to automatically design robots to move autonomously on a horizontal plane by utilizing evolutionary computation. The output of their software consists of STL files for input directly to an FDM machine. Joints were fabricated in already assembled form, and actuators and sensors were assembled to the robots after fabrication.

Successful insertion of embedded electronic components in RP during the build process was reported for electronic games already in 1992 (Beck et al., 1992). Several research groups are seeking to apply this idea, i.e. the insertion of components during the build process, to the fabrication of mechanisms in RP. By inserting actuators and sensors during the build process and using non-assembly joints, no assembly is required after the build process. A group at Stanford University developed a design framework for this purpose, termed “Design by Composition for Rapid Prototyping”, see Binnard (1999) and related research by Binnard & Cutkosky (1998) and Cham et al. (1999). A group at Georgia Tech developed design strategies for the insertion of components for SL Technology, see Kataria (2000) and Kataria & Rosen (2000). Furthermore, the conceptual design of enhanced stereolithography machines, that may better support the insertion of components in the future, was discussed by Geving et al. (2000) and Geving & Ebert-Uphoff (2000).

## 4. Rapid Prototyping of Mechanisms Using Fused Deposition Modeling

This section presents the rapid prototyping of mechanisms using a commercially available CAD package and a FDM rapid prototyping machine. A database of lower kinematic pairs (joints) is developed using the CAD package and parameters of fabrication are determined experimentally for each of the joints. These joints are then used in the design of the prototypes where the links are developed and adapted to the particular geometries of the mechanisms to be built. Also, a procedure is developed to build gears and Geneva mechanisms. Examples of mechanisms are then studied and their design is presented. For each mechanism, the joints are described and the design of the links is discussed. Some of the physical prototypes built using the FDM rapid prototyping machine are shown.

### 4.1 Lower Kinematic Pairs and their Fabrication

The main distinction between the rapid prototyping of mechanical parts and the rapid prototyping of robotic mechanisms is the need to include moving joints in the latter. Joints are undoubtedly the most critical components of robotic mechanisms and the effectiveness of prototypes of robotic mechanisms is largely dependent on the ability to produce joints with adequate accuracy. Hence, the prototyping of moving joints is at the core of this work and will be addressed first.

Before mechanisms can be built, a database of lower kinematic pairs (joints) is developed and experimentally tuned. These joints will constitute the building blocks which will then be adapted and scaled to be included in specific mechanisms. These lower kinematic pairs are the revolute, Hooke, spherical, prismatic and cylindrical joints. These joints are the most critical parts of the mechanisms.

Because of the anisotropy of the material deposited layer by layer, the parts must be properly oriented to obtain the desired strength. This is not only true for joints but for all parts. This can be observed in Figures 1 (b) and 3, where the same part is properly oriented in Figure 1 (b) and not properly oriented in Figure 3. Deposition layers oriented perpendicular to a hole axis increase the strength of the hole. For example, the holes in the part of Figure 1 (b) are strong compared to the holes in the part of Figure 3. Deposition layers oriented perpendicular to a pin axis decrease the strength of the pin. For example, the pins at the right end of the part are strong in the part of Figure 1 (b) but fragile in the part of Figure 3. Since the joints involve moving contacts, the dimensional accuracy and the surface

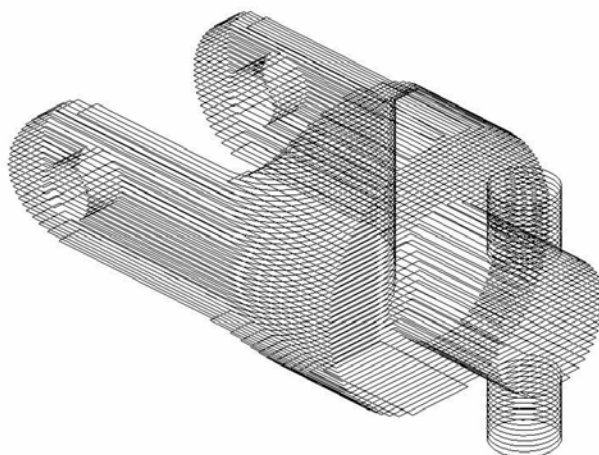

Figure 3. Example of a sliced part not properly oriented

finish are critical. The tolerance of the parts is  $\pm 0.005$  inches (0.127mm), which is relatively large for moving joints. Also, it can be seen from experimentation that a cylinder built horizontally is oval instead of circular. To obtain proper performances, test parts are built with progressive clearances, assembled and tested. Moreover, because the parts are built in layers of 0.010 (0.254mm) inches, the surfaces that are not perfectly vertical will include "steps" associated with the layers and their surface finish will be rather poor in the directions not aligned with layers. Therefore, it is advantageous to keep the walls perfectly vertical or to keep sliding movements aligned with the layers. For example, as can be seen in Figures 1 (b) and 3, the holes and shafts are smoother when their axis is perpendicular to the orientation of the deposition layers.

As previously mentioned, mechanisms built with the FDM process are built in separate parts and assembled manually. Most of the joints are assembled using the elastic deformation of the material. Therefore, a compromise must be found between the stiffness of the joints and their ability to be assembled without rupture. The maximum elastic deformation has been found to be around 1.5%, but deformations of 3%—with some plastic deformation—are acceptable if necessary. Some features of the geometry of the parts are established using stress-deformation equations.

Finally, some joints may have very deep and narrow holes and it would be very difficult to remove the support material. Fortunately, with the FDM process, it is possible to make what is referred to as bridging. With appropriate settings, the hot thread of material is stretched and does not collapse for a short distance (up to 6 mm) when it is applied without support. Therefore, it is possible to build small ceilings without support. To establish the maximum bridging distance without collapse, a test part with different gap lengths is built without support in the gaps. This is illustrated in Figure 4. Note that the threads of the layer covering the gaps are oriented in the longitudinal direction of the part to make bridging possible.

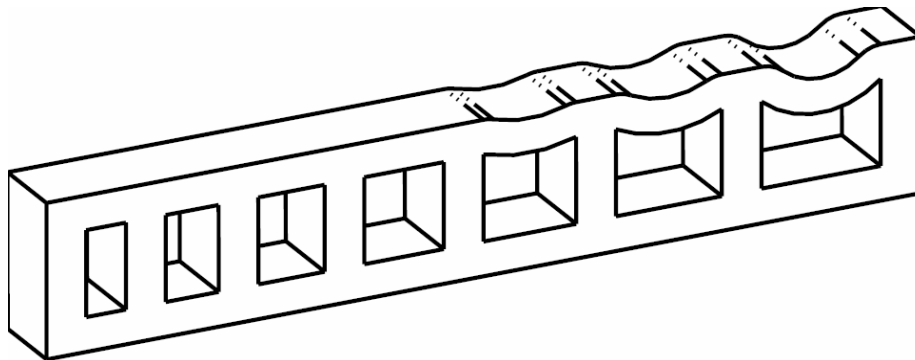

Figure 4. Bridging test : the bridging is correct up to the fourth gap

The database of joints is now described:

### *Revolute Joints*

Two types of revolute joints are represented in Figure 5 (a) and (b).

The first type of revolute joint is made of a grooved shaft to be inserted in a hole and held by a snap ring. The snap ring can be bought or made by the rapid prototyping machine. It is preferable to build the part with the hole aligned vertically in order to obtain a stronger part and a rounder and smoother hole. It is better to build the shaft horizontally to improve its strength. However, it is preferable to build it vertically to produce a part with



better smoothness and roundness. Most of the time, the shafts are built horizontally since strength is more critical.

The second type of revolute joint is made of a fork-shaped part with two small shafts and a hole. The fork is opened to fit the small shafts at the ends of the hole. Again, it is better to build the part with the hole vertically to obtain a stronger part and a smoother hole. Since the shafts are placed on each side of the part, they work only in shear stress, which is less demanding than the bending stress sustained by the first type of joint. Therefore, the shafts are built vertically. The shape of the fork is an important factor to obtain adequate stiffness while providing sufficient compliance for the assembly. Note that this type of joint is very smooth but cannot be rotated 360 degrees. Upon fabrication, the first type of joint is assembled by inserting the shaft in the hole and snapping the ring in the groove. The second type of joint is assembled by opening the fork and snapping the shafts of the moving part in the holes.

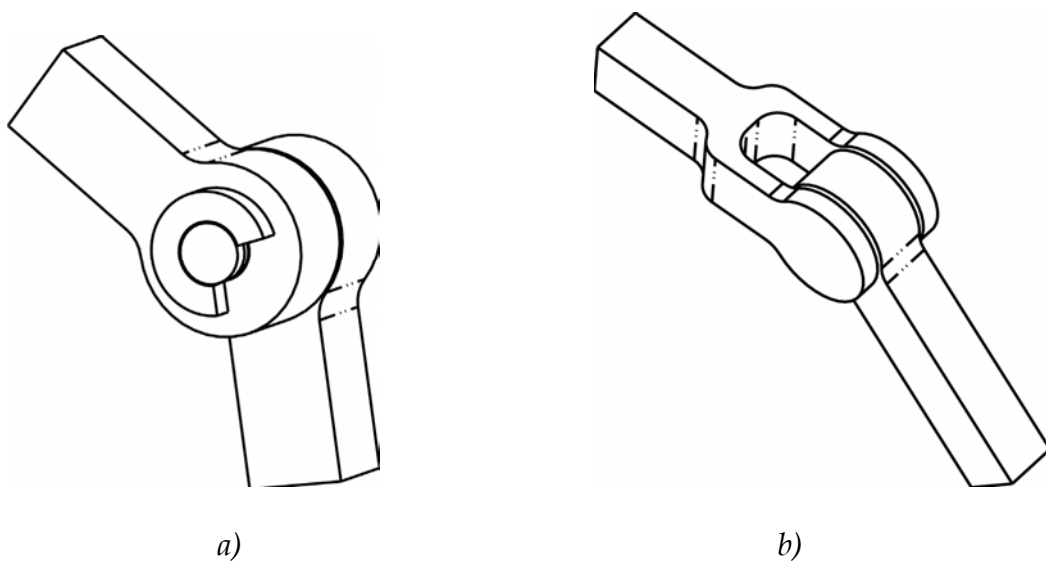

Figure 5. Revolute joints: (a) type 1 (b) type 2

A Hooke joint is represented in Figure 6. The Hooke joint is composed of a small cross and two fork-shaped parts. Upon fabrication of the three parts, the joint is assembled as follows: the pins of the cross are inserted in the holes of the fork-shaped parts by opening the fork.

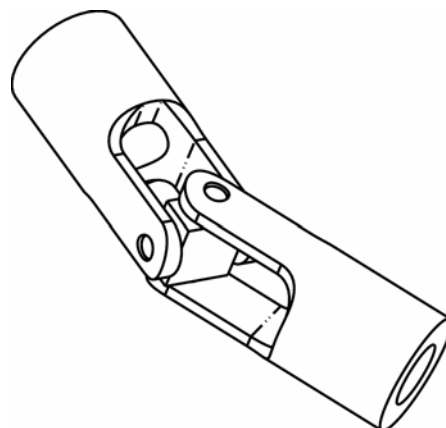

Figure 6. Hooke joint

The forks are built with the holes vertically oriented for strength and roundness. The pins of the cross are built horizontally for strength. Again, the shape of the fork is an important factor to obtain proper stiffness while providing sufficient compliance for the assembly. The Hooke joints can be suitably operated at  $\pm 45$  degrees.

### *Spherical Joints*

A spherical joint is represented in Figure 7. The spherical joint is made of a sphere at the end of a cylinder and a spherical cap segmented in four sections to allow some expansion during the assembly. The assembly of the joint is performed by pushing the sphere into the spherical cap. The cap is preferably built horizontally to give more strength to the sections. The sphere and its cylinder are preferably made of two parts. The cylinder is built horizontally for strength. The sphere is built perpendicular to the cylinder to keep the layers of the sphere and the layers the cap unaligned in all configurations to avoid any gripping. These parts are then assembled press fit or bound. The spherical joint can be operated in a cone of  $\pm 30$  degrees.

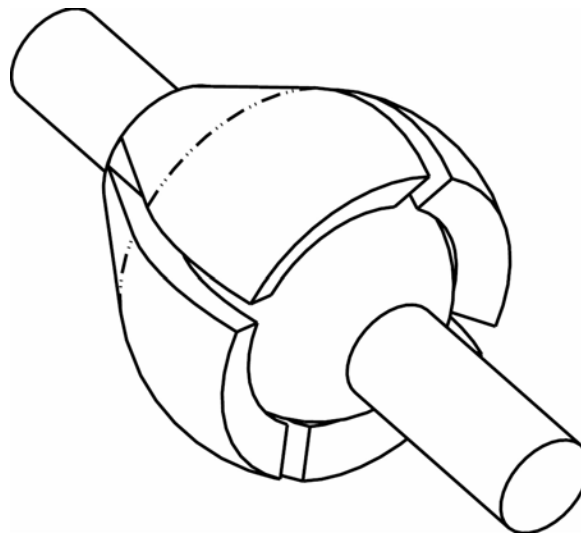

Figure 7. Spherical joint

### *Prismatic Joints*

A prismatic joint is represented in Figure 8 (a). The prismatic joint is made of a square section and its corresponding square tube. In order to obtain proper strength, both parts must be built horizontally. Therefore, the tube should be filled with support material to support the roof of the square tube. Since the tube can be very deep and narrow, it would be very difficult to remove the support material and bridging is used. A groove is made along the bar, except at the ends. A small flexible stopper is made at the end of the tube and inserted into the groove to keep the motion of the bar in a certain range. The two parts are assembled as follows: the stopper is maintained open to allow the insertion of the bar in the tube. For some applications, it is interesting to have a prismatic joint that can keep a certain position even if there is some force applied on it (for instance, to avoid the collapsing of a prototype under gravitational forces). This can be accomplished by creating a wave along the sliding bar and a flexible rod on the tube. The rod will tend to stay in the trough of the waves, allowing to keep given configurations. This is illustrated in Figure 8 (b).

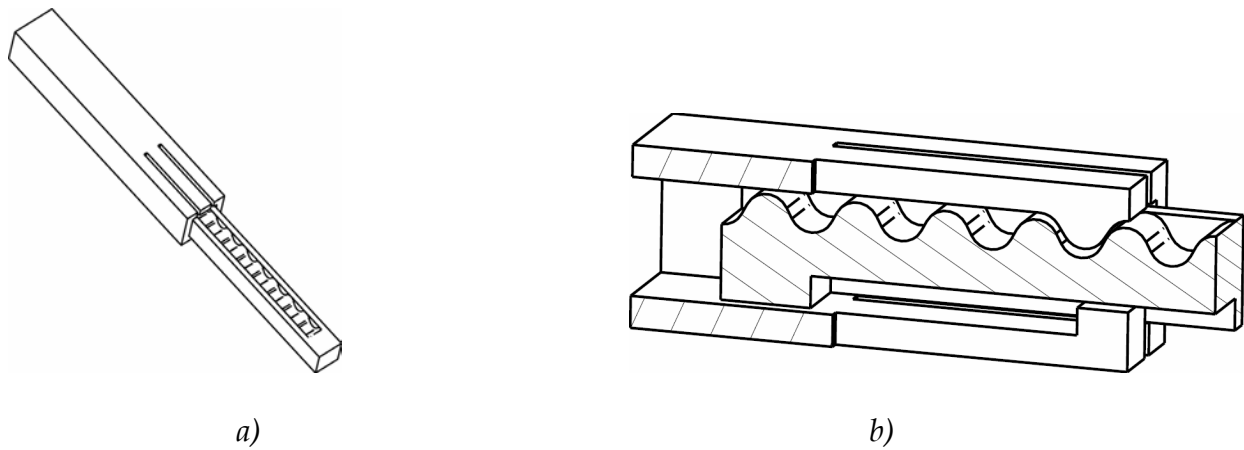

Figure 8. (a) Prismatic joint with wavy moving bar. (b) Zoomed cross section of the prismatic joint with the wave mechanism (top) and the stopper (bottom)

### *Cylindrical Joints*

A cylindrical joint is represented in Figure 9. The cylindrical joint is made of a rod inserted in a tube. As for the prismatic joint, both parts must be built horizontally in order to obtain proper strength. For the tube, bridging is used to avoid use of support material. Since the roof is not planar, the shape of the tube is modified to allow bridging without affecting the desired properties. In order to stop the travel of the joint and allow a smooth rotation, a press-fit sleeve is added to the rod and a press-fit cap is added to the tube.

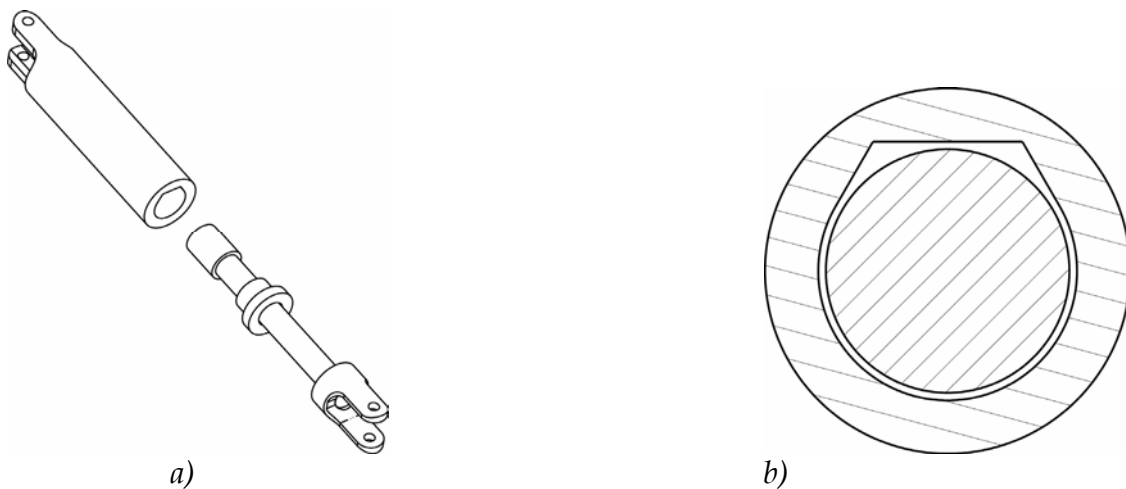

Figure 9. (a) Cylindrical joint with parts of Hooke joints at the ends. (b) A cross section of the cylindrical joint illustrates the shape of the tube to allow bridging

## **4.2 Rigid Assembly of Parts**

In the fabrication of mechanisms, parts must often be rigidly assembled. Indeed, some parts are too large to be built in one piece and different features of a same part must sometimes be oriented in different directions to accommodate the anisotropy of the material. However, some assemblies should not be permanently mounted, in order to allow many versions of a part of an assembly to be exchanged. To assemble the parts permanently, glue or strong press fit has shown to be satisfactory. Some non-permanent assemblies have also been developed, as light press fit. Another example, the twist binder,

represented in Figure 10, is useful to easily mount and unmount parts where the translating forces are important but the torque in at least one direction is weak or zero.

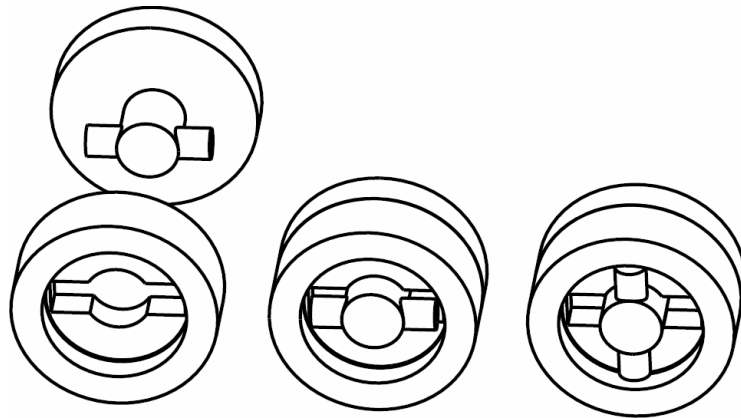

Figure 10. Twist binder : a T-shaped part is inserted in a slotted part, then turned 90 degrees to a press-fit locked position

### 4.3 Gears

This section discusses the fabrication of spur gears with teeth made using the commonly used involute profile. The theory related to involute gearing will be shortly summarized for the rapid prototyping needs. The following values are known: the diametral pitch  $P_d$ , the pressure angle  $\Phi$  and the number of teeth  $N$  or the pitch diameter  $D_p$ . These two last values are related by  $P_d = N/D_p$ . The following values are then computed : outside diameter is  $D_o = D_p + (2/P_d)$ , the root diameter is  $D_r = D_p - (2.5/P_d)$ , the base diameter is  $D_b = D_p \cos \Phi$  and the thickness of the tooth is  $t = \pi/2P_d$ . Note that while  $D_i$  refers to diameter values,  $R_i$  refers to the corresponding radius value. For more details refer to Oberg et al. (1988). To create the gear teeth in the CAD package, a skeleton curve of the involute profile must first be defined parametrically. Referring to Figure 11, the involute curve can be described by

$$X = -R_b \sin(\alpha - \beta) + R_b \cos(\alpha - \beta) \quad (1)$$

$$= R_b \cos(\alpha - \beta) + R_b \sin(\alpha - \beta) \quad (2)$$

where  $R_b$  is the base radius,  $\alpha$  is the parametric angle and  $\beta$  is an offset angle related to the thickness  $t$  of the tooth. The parametric angle  $\alpha$  varies from 0 to  $\alpha_o$ , which is related to the outside diameter of the gear  $D_o$ . The values of  $\beta$  and  $\alpha_o$  are found from the following equations.

$$= \pi/2N + \tan(\Phi) - \Phi - V/R_p \quad (3)$$

$$\alpha_o = \tan[\arccos(D_b/D_o)] \quad (4)$$

where  $V$  is an offset to allow sufficient backlash. Good results are obtained with  $V = 0.001$  inch (0.0254 mm).

With these equations and some experiments, a procedure has been developed for the CAD package.

1. Extrusion of a circle of diameter  $D_b$  if  $D_b > D_r$  or  $D_r$  if  $D_r > D_b$ .
2. Creation of a coordinate system (see Figure 11).

3. Creation of the parametric involute curve found from the preceding equations.
4. Mirror copy of this curve from the plane YOZ.
5. Creation of an outside diameter circle.
6. Extrusion of the tooth from the parametric involute curves and the outside diameter circle.
7. Copy of this tooth each  $360/N$  degrees.
8. If  $D_r < D_b$ , creation of a cut between the teeth to  $D_r$  and copy of this cut.
9. Creation of fillets, holes, hubs, etc.

A similar and adapted procedure can be used to obtain internal spur gears. Regarding the orientation of the gears in the prototyping machine, it is advantageous to keep their axis vertical for smoothness of operation and strength. With proper adjustment of the parameters of the rapid prototyping machine, gears with diametral pitch as fine as 32 (approximately 0.8 module) can be properly fabricated and used. Future work includes the development of helical, miter and bevel gears.

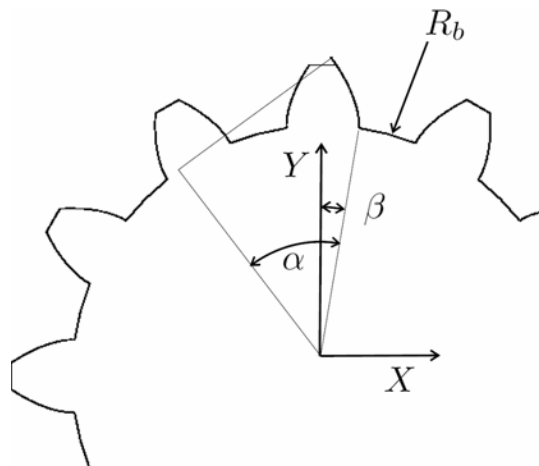

Figure 11. The involute profile of a gear tooth

#### 4.4 Examples of Mechanisms Using FDM

To build a complete mechanism, one has to create the appropriate links and include the joints presented previously. Because of the nature of the rapid prototyping process, these links can be of almost any shape. Here, the anisotropy of the material is the main factor to be considered in order to obtain links of appropriate strength. This section presents some examples of mechanisms built in the Robotics laboratory at Laval University using the joints previously presented. In addition to the mechanisms presented here, the following mechanisms have been built: four-bar and five-bar spherical mechanisms, four-bar spatial mechanisms, serial manipulators, 3-DOF planar parallel mechanism, 3-, 4- and 5-DOF spatial parallel mechanisms and several others.

##### *Simple Mechanisms*

Several simple mechanisms have been built. The Bennett linkage is a good example. A prototype of the Bennett mechanism (Phillips, 1990) – a well known spatial four-bar overconstrained linkage – has been built for classroom demonstration purposes. The CAD model and the prototype are presented in Figure 12 (a) and (b).

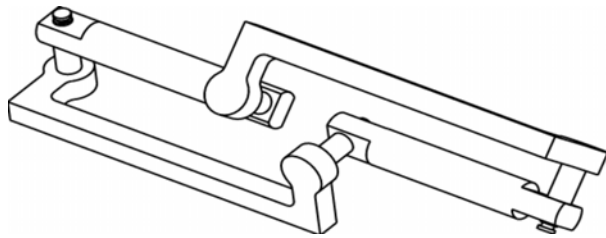

a)

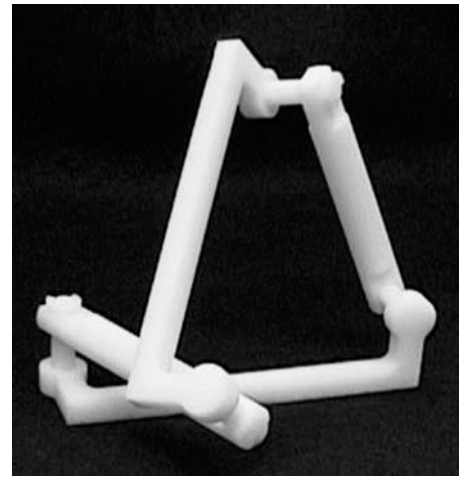

b)

Figure 12. Bennett mechanism: (a) CAD model (b) prototype

### *Three-DOF Spherical Mechanism: the Agile Eye*

The Agile Eye (Gosselin & Hamel, 1994), represented in Figure 13 (a) and (b), is an example of mechanism involving complex geometries that are easily made with rapid prototyping. Each of the three legs has three revolute joints. Note that the bottom link of the legs is made of two parts in order to align the layers with the general orientation of the legs.

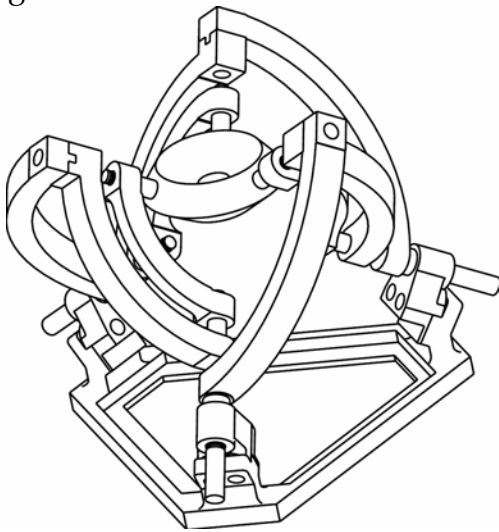

a)

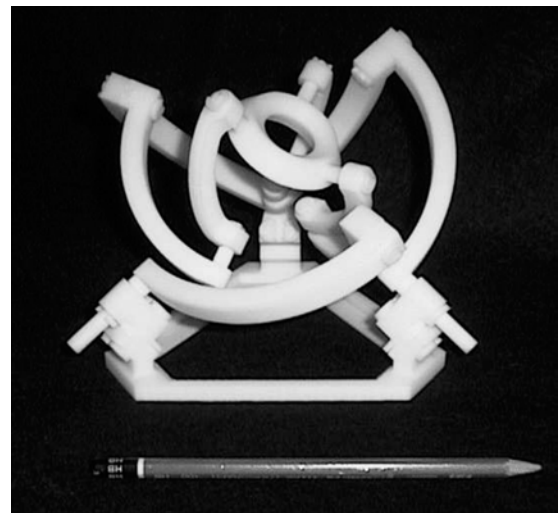

b)

Figure 13. Agile eye: (a) CAD model (b) prototype

### *Three-DOF, Four-DOF, Five-DOF and Six-DOF Platforms*

Several three-, four-, five- and six-DOF parallel platforms have been built. For instance, the six-DOF (Gough-Stewart) (Dasgupta & Mruthyunjaya, 2000) platform illustrates the use of a variety of the joints developed above (Figure 14 (a) and (b)). Each of the legs comprises a Hooke joint, a prismatic joint and a spherical joint, giving 6 DOF. The ends of the legs can be assembled to the upper and lower platforms using a twist binder. With these binders, the legs and the platforms are modular. Therefore, it is easy to try different geometries of

platforms or different types of legs without having to rebuild the whole mechanism for each version. The plastic prototypes of parallel robotic mechanisms are very useful to visualize the singularities. In general, singularities can be found from mathematical analysis but are often difficult to physically visualize.

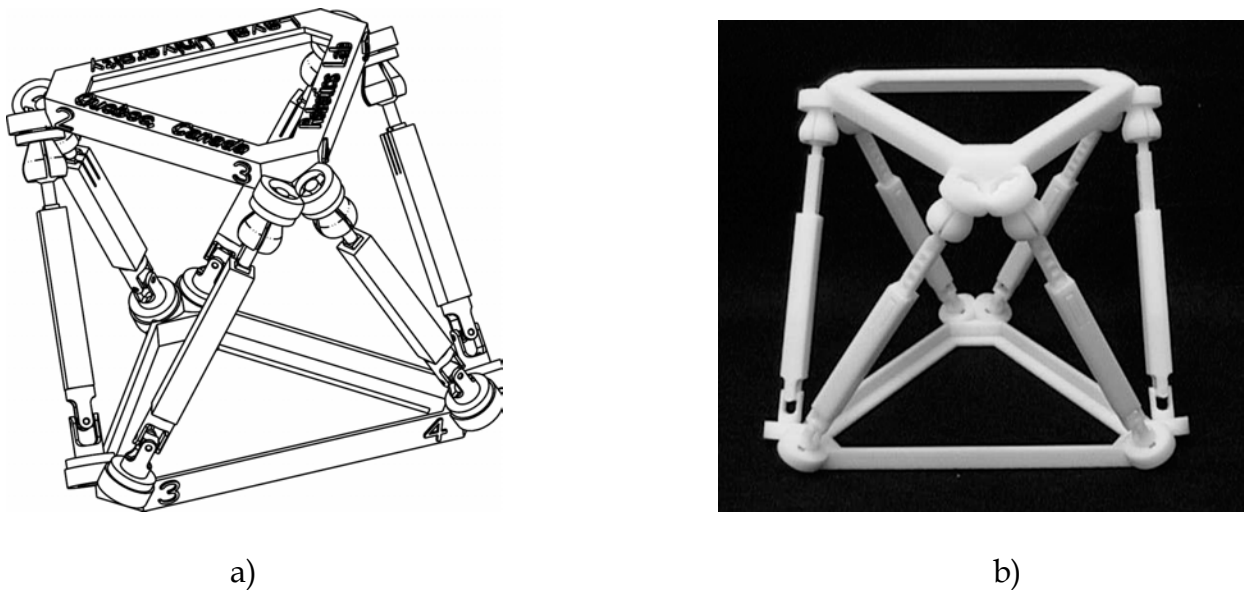

Figure 14. Gough-Stewart platform: (a) CAD model (b) prototype. Note the use of waves in the prismatic joints to avoid collapse of the platform

*Example of Geared-Pair Mechanism: Planetary Gear System*

The rapid prototyping of gears is useful for the development of complex systems. For example, a planetary gear system is presented in Figure 15. This planetary gear system is made with a 2-inch (50.8 mm) internal gear and 24 diametral pitch (approximately 1.0 module) teeth. The prototype works very smoothly. Gears with 48 diametral pitch (approximately 0.5 module) teeth or finer are difficult to obtain because of the resolution of the machine.

*Examples of Actuated Mechanisms*

Some of the prototypes built are motorized, as the novel 6-DOF mechanism (Gosselin et al., 1999) represented in Figure 16 (a) and (b). Since larger stresses can be generated at the actuator shafts, an aluminum part is mounted on the shafts and then inserted in the ABS part. All the other joints of the mechanism are in ABS polymer and could

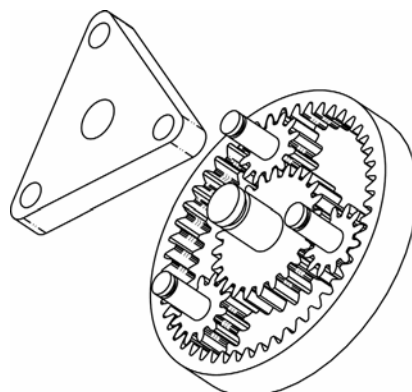

Figure 15. CAD model of a planetary gear system

easily sustain the induced forces even when the end-effector of this mechanism experienced accelerations of more than one g. Another example is a 3-DOF spherical haptic device with only pure rotations of the end effector, represented in Figure 17 (a) and (b). In this prototype, metal parts and bearings are used in combination with plastic parts. The main advantage of rapid prototyping in this example is the complexity of the geometry of the moving parts, some of which would be extremely difficult to machine using conventional processes. Although satisfactory results have been obtained with this spherical haptic device, the compliance of the plastic parts remains an important limitation if high performance is required.

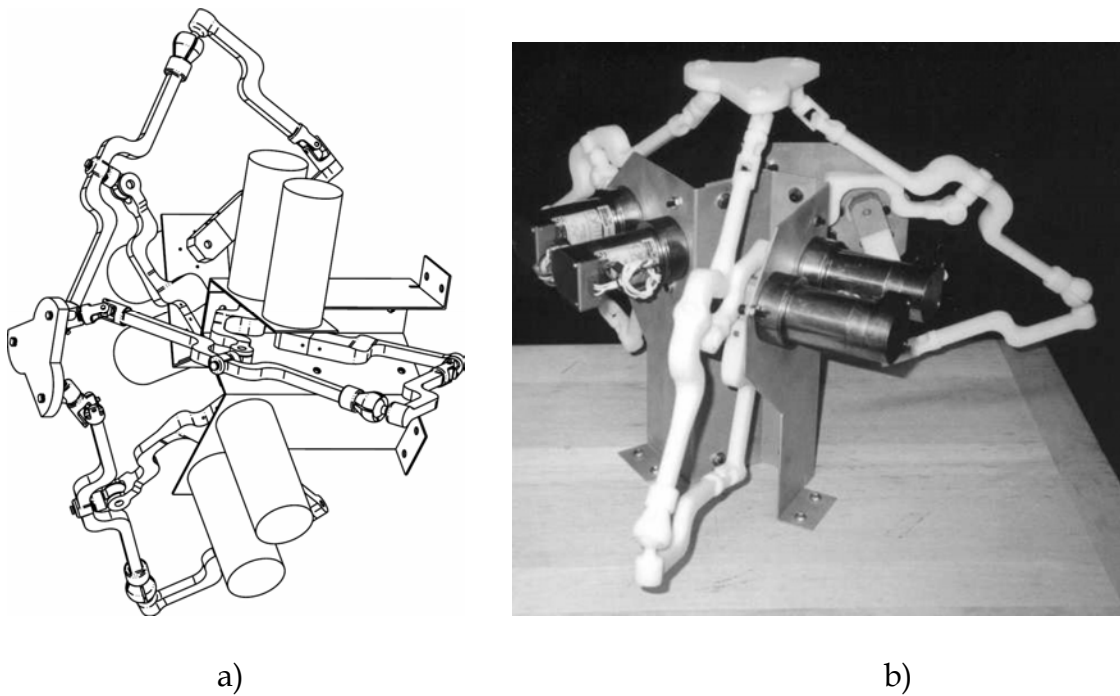

Figure 16. Novel six-DOF mechanism: (a) CAD model (b) prototype

*Prototyping of a Robotic Hand*

The rapid prototyping technique presented above has been especially useful in the design of a robotic hand (Laliberté & Gosselin, 2001, 2003), illustrated in Figure 18.

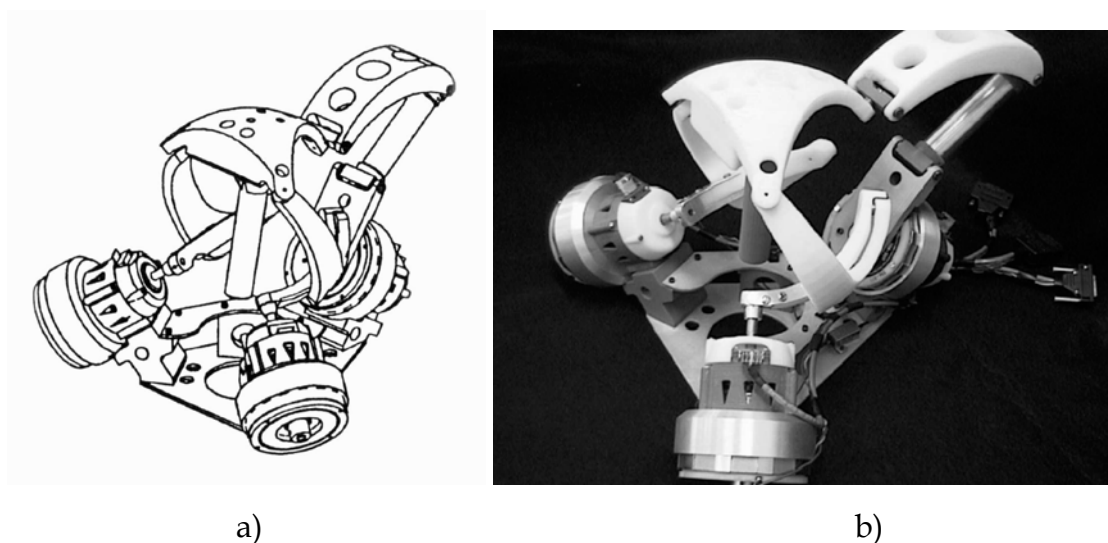

Figure 17. Three-DOF spherical haptic device: (a) CAD model (b) prototype



Several novel features are included in this versatile grasping hand, which has ten degrees of freedom but only two actuators.

Plastic models of the new features have been built during the first steps of the design process in order to validate their functionality or to help choosing among several possible solutions which were difficult to compare by simulation. Among others, prototypes of fingers were very useful to check possible mechanical interferences between the numerous parts of the compact assembly. Also, the prototyping of a new geared differential system has been useful for validation and demonstration.

The prototype of the robotic hand has been built almost entirely of plastic except for off-the-shelf metal screws, nuts and springs. The number of parts, without the screws, retaining rings and bushings, is approximately 200. The prototype has been tested to validate its functionality and real grasping tasks were performed using actuators. If a part of a sub-system was not satisfactory, it was modified on the CAD software, rebuilt and assembled, generally in the same day, making the tuning cycle very short. The mechanical efficiency of the system has been measured and compared with the simulation results in order to validate the theoretical model of the grasping forces. In order to identify the weakest parts of the system, the hand has been overloaded. The resulting broken part could then be modified. As should be expected, the load that could be applied on the plastic prototype was much lower than for the metal version. However, knowing the relative strength of the plastic and metal, test data could be extrapolated.

For instance, one particular part with a very complex shape was tested mechanically using the plastic prototype since its resistance was difficult to obtain through simulation. For the fabrication of the real metal hand, the plastic prototype was a very good complement to the drawings. First, the design of the metal hand was completed with much more confidence from the validation and testing of the plastic prototype. Also, the plastic parts were used to help the machinists understand the most complex geometries before they fabricated the metal parts.

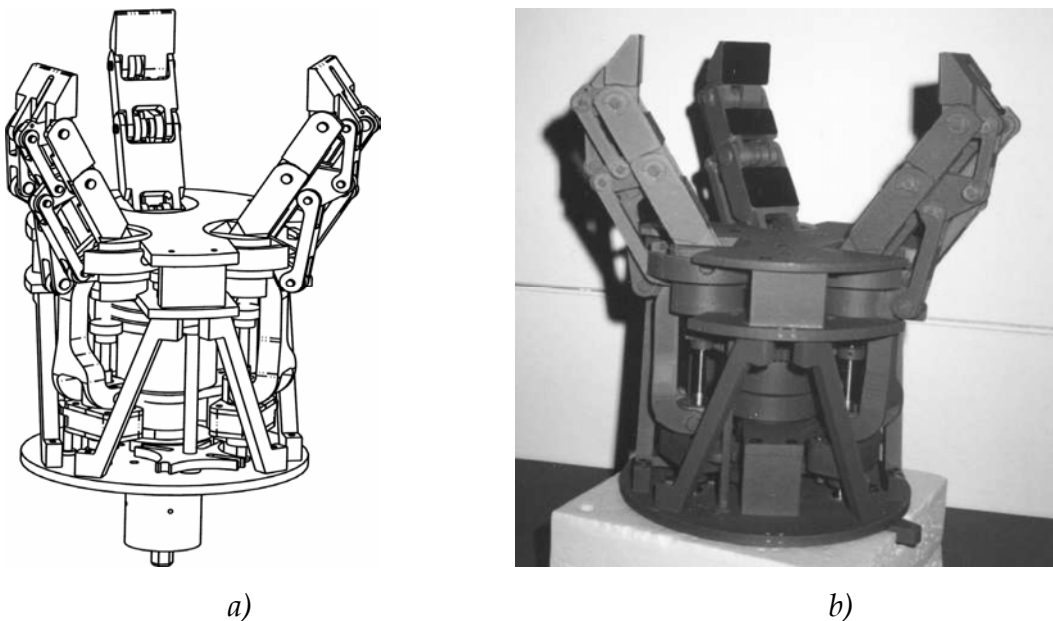

Figure 18. Underactuated 10-dof robotic hand: (a) CAD model (b) prototype

The prototype has been a remarkably useful tool for explanation and demonstration purposes. Also, the plastic prototype made it possible to apply for a patent with confidence before the construction of the metal version was completed.

## Thank You for previewing this eBook

You can read the full version of this eBook in different formats:

- HTML (Free /Available to everyone)
- PDF / TXT (Available to V.I.P. members. Free Standard members can access up to 5 PDF/TXT eBooks per month each month)
- Epub & Mobipocket (Exclusive to V.I.P. members)

To download this full book, simply select the format you desire below

