

Distributed Architecture for Intelligent Robotic Assembly

Part III: Design of the Invariant Object Recognition System

Mario Pena-Cabrera and Ismael Lopez-Juarez

1. Introduction

In previous chapter it has been described the overall architecture for multimodal learning in the robotic assembly domain (Lopez-Juarez & Rios Cabrera, 2006). The acquisition of assembly skills by robots is greatly supported by the effective use of contact force sensing and object recognition. In this chapter we will describe the robot's ability to invariantly recognise assembly parts at different scale, rotation and orientation within the work space. The chapter shows a methodology for on-line recognition and classification of pieces in robotic assembly tasks and its application into an intelligent manufacturing cell. The performance of industrial robots working in unstructured environments can be improved using visual perception and learning techniques. In this sense, the described technique for object recognition is accomplished using an Artificial Neural Network (ANN) architecture which receives a descriptive vector called CFD&POSE as the input. This vector represents an innovative methodology for classification and identification of pieces in robotic tasks, every stage of the methodology is described and the proposed algorithms explained. The vector compresses 3D object data from assembly parts and it is invariant to scale, rotation and orientation, and it also supports a wide range of illumination levels. The approach in combination with the fast learning capability of ART networks indicates the suitability for industrial robot applications as it is demonstrated through experimental results.

Open Access Database www.i-techonline.com

Robotics field has grown considerably with new technologies, industrial robots today, needs sensorial capabilities to achieve non-structured and more sophisticated tasks; vision systems as a sensorial mode for robots have a growing demand requiring more complex and faster image processing functions in order to implement more sophisticated industrial applications, like assembly automation.

In this sense, vision recognition systems must be capable of perceiving and detecting images and objects, as close as the human vision does; this fact has encouraged research activity to design artificial vision systems based on the neural morphology of the biological human vision system. Now scientists understand better about how computational neural structures and artificial vision systems must be designed following neural paradigms, mathematical models and computational architectures. When a system involves these aspects, it can be referred to as a “Neuro-Vision System” (Gupta and Knopf, 1993), (Peña, 2004), which can be defined as an artificial machine with ability to see our environment and provide visual formatted information for real time applications.

It has been shown by psychological and clinical studies that visual object recognition involves a large activity area on the cerebral cortex when objects are seen the first time and the region’s activity is reduced when familiar objects are perceived (Gupta and Knopf, 1993). New objects can also be learned quickly if certain clues are given to the learner. Following this psychological evidence a novel architecture was designed. The architecture is firstly trained with clues representing different objects that the robot is likely to encounter within the working space to form its initial knowledge base. This information then triggers the on-line learning subsystem based on an Artificial Neural Network (ANN), the new image vector descriptors override initial clues, and the robot learns to identify familiar objects and to learn new ones.

The above ideas suggested that it was possible to get fast and reliable information from a simple but focused analysis of what an object might show. The very important aspects of the scene (we have called “clues”), can be used later to retrieve memorized aspects of the object without having to recall detailed features. By using neural networks it is possible to learn manipulative skills which can be used by an industrial manipulator (Lopez-Juarez and M. Howarth, 2000). In some way we humans do that process once an object has been seen and learned for the first time.

The chapter describes a methodology for on-line object recognition, based on artificial neural networks for identification and classification purposes. Robust algorithms for perimeter, centroid calculations, object functions and pose estimation are presented.

2. Related work

Intelligent manufacturing cells using robots with sensorial capabilities are being investigated using Artificial Intelligence techniques like ANN's and Fuzzy Logic among others, since mathematical and control models are simplified.

Acquiring information from multiple sensors in manufacturing systems provides robustness and self-adaptation capabilities, hence improving the performance in industrial robot applications. A few researchers have applied neural networks to assembly operations with manipulators and force feedback. (Vijaykumar Gullapalli, 1994), used BackPropagation (BP) and Reinforcement Learning (RL) to control a Zebra robot, its neural controller was based on the location error reduction beginning from a known location, (Enric Cervera, 1997), employed Self-Organization Map (SOM) and RL to control a Zebra robot, the location of the destination piece was unknown, (Martin Howarth, 1998), utilized BP and RL to control a SCARA robot, without knowing the location of assembly, (Lopez-Juarez, 2000), implemented FuzzyARTMAP to control a PUMA robot also with an unknown location. All of the above authors considered only constraint motion control during assembly; however, to complete the autonomy of the assembly system a machine vision system has also to be considered. Additionally, a new concept was introduced in 1988 called "Robotic Fixtureless Assembly" (RFA) (Hoska, 1998), that eliminates the need of using complex and rigid fixtures, which involves new technical challenges, but allows very potential solutions. Studies of RFA of flexible parts with a dynamic model of two robots which does not require measurements of the part deflections have been done (W. Ngyuen and J.K. Mills, 1996). (Plut, 1996), and (Bone, 1997), presented a grasp planning strategy for RFA. The goal of RFA is to replace these fixtures with sensor-guided robots which can work within RFA workcells. The development of such vision-guided robots equipped with programmable grippers might permit holding a wide range of part shapes without tool changing. Using Artificial Neural Networks, an integrated intelligent vision-guided system can be achieved as it is shown by (Langley et al., 2003). This job can be achieved by using 2D computer vision in different manner so that 3D invariant object recognition and POSE calculation might be used for aligning parts in assembly tasks if an "adequate descriptor vector" is used and interfaced in real time to a robot. Many authors had come with descriptor vectors and image transformations, used as general methods for computer vision applications in order to extract invariant features from shapes.

(Alberto S. Aguado et al., 2002), developed a new formulation and methodology for including invariance in general form of the Hough transform, (Chin-Hsiung et al., 2001), designed a technique for computing shape moments based on the quadtree representation of images, (P. J. Best and N. McKay, 1992), describe a method for registration of 3D shapes in minutes, (A. Torralba and A. Oliva, 2002), present a method to infer the scale of the scene by recognizing properties of the scene structure for depth estimation, (Freeman, 1961), introduced the first approach for representing digital curves using chain codes, and showing classical methods for processing chains (Freeman, 1974), (E. Bribiesca, 1999), developed a new chain code for shapes composed of regular cells, which has recently evolved even to represent 3D paths and knots.

Some authors use multiple cameras or multiple views to extract information, performs invariant object recognition and determine object's position and motion, (Stephen A. Underwood, 1975), developed a visual learning system using multiple views which requires deterministic description of the object's surfaces like measurements and interconnections, (Yong-Sheng Chen et al., 2001), propose a method to estimate the three dimensional ego-motion of an observer moving in a static environment, (Hiroshi Murase and Shree K. Nayar, 1995), have worked in visual learning and recognition of 3D objects from appearance, (E. Gonzalez-Galvan et al., 1997), developed a procedure for precision measure in 3D rigid-body positioning using camera-space manipulation for assembly. (Dickmanns, 1998), and (Nagel, 1997), have shown solutions to facilitate the use of vision for real world-interaction, (Hager et al., 1995), and (Papanikolopoulos et al., 1993), use markers on the object to simplify detection and tracking of cues.

Some other authors have contributed with techniques for invariant pattern classification, like classical methods as the universal axis of Lin, and invariant moments of (Hu, 1962), or artificial intelligence techniques, as used by (Cem Yüceer and Kemal Oflazer, 1993), which describes an hybrid pattern classification system based on a pattern pre-processor and an ANN invariant to rotation, scaling and translation, (Stavros J. and Paulo Lisboa, 1992), developed a method to reduce and control the number of weights of a third order network using moment classifiers and (Shingchern D. You and G. Ford, 1994), proposed a network for invariant object recognition of objects in binary images. Applications of guided vision used for assembly are well illustrated by (Gary M. Bone and David Capson, 2003), which developed a vision-guide fixtureless assembly system using a 2D computer vision for robust grasping and a 3D computer

vision to align parts prior to mating, and (Stefan Jörg et al., 2000), designing a flexible robot-assembly system using a multi-sensory approach and force feedback in the assembly of moving components.

3. Invariant Object Recognition

Recognising an object using a vision system involves a lot of calculations and mathematical processes which have to be implemented and tested in order to be used in a real application. In this way, vision systems and solid state technologies has been evolved at the same time, the more faster and sophisticated computers had come with the more complex and better vision systems developed as well as more sophisticated algorithms implementation had became a reality.

Basic ideas were established with approximated representations, architectures and algorithms, which motivated the development of this research area. A general solution to the recognition problem does not exist (J. L. Mundy, 1998). Most classical methods to object recognition use shape analysis and metric feature extraction from digitized images to reach the goal. Recent research, points to use artificial intelligence techniques to look for invariant recognition solutions using vision. In this way artificial neural networks are a well representative technique to this purpose

3.1 Learning

For a better understanding of the recognition problem, it is convenient to explore how humans make the recognition process, sometimes in an automatic manner and many times in short periods of time, as it is the case of a projected image in the retina which can be rotated, moved or even scaled when the object or eyes are moved. Humans can recognize an object within a complex scene with overlapped objects.

Most recognition techniques uses indirect mapping between objects and retinal images, there is a set of object representations in long term memory which have been associated with object physical representations, and information is not just a copy of a pattern of retinal stimulus but a set of features representative of the object with invariant properties, so the object can be recognized from different views. There must be a criteria to decide which is the best object representation within the long term memory when an input object representa-

tion is not exactly the same to the one already memorized. It is difficult to know when the perception process ends and when the recognition process begins.

Human visual process can execute a universal set of routines with simple sub-processes operating with object sketches even in 2 ½ dimensions (S. Ulman, 1984), this activities might involve: contour scanning, region filling and area marking to obtain as the output, basic features from the most important issues of a visual scene as shapes and its spatial relation, this goes to the process of object recognition by way of its parts grouping reconstruction, because objects can be overlapped or occluded. Assuming that memorized parts corresponds to previous visual learning processes, a shape can be addressed and reconstructed with a huge part list, so recognition can be achieved using only the visible parts within the scene.

3.2 Memory and Recall

There are at least two different processes to storage information in the long term memory. The first process is to store a list of situations about the objects including information on how many parts are grouped together, its size, category names and so on. The other process is to store the codification of object appearance. There is evidence that the time a person takes to decide if two 3D objects have the same shape is a linear function of its orientation difference (R.N. Shepard and S. Hurwitz, 1984). This information might be understood as the humans falls in a continuous and smooth rotation mental process which is achieved until the orientation input shape, matches the correct canonical orientation of shape already stored.

A person cannot see an object in a single view from an arbitrary view angle, in fact, first the object is visualized with a canonic orientation to be rotated to the specific orientation, this suggests the idea that long term memory image representations are oriented to a primitive and primary observation stored as canonical shapes, which is an important point to our research inspiration.

3.3 Design considerations and techniques

In order to design and implement a vision system and use the appropriate techniques in the visual process, three aspects might be considered:

- Vision is a computational process
- Obtained description of object is a function of the observer
- Not used information within the scene has to be eliminated

Because vision is a complex process different vision levels are established for better methodology directions:

- Low level processing.- pixel direct working is done in this level to extract properties as: edges, gradients, textures, grey levels, etc.
- Medium level processing.- elements of low level are grouped here to obtain lines, regions of interest in order to use segmentation techniques.
- High level processing.- it is oriented to interpretation of lower levels Information using models and previous knowledge. It has to deal with recognition and looks for consistency on feature primitive in formation interpretation.

Representation is a formal system to specify features of what is seen with a vision system, two aspects are important:

- a) *the model representation*, is the structure used to model the representation
- b) *the recognition process* is the way the model and representation are used for recognition.

These aspects have to be generic, time and space efficient, rotation, translation and scaled invariant, and conform robustness and noise and incomplete information tolerance. High level vision systems can be classified in:

- Model based vision systems.- use a geometrical representation and recognition is based on correspondence.
- Knowledge based vision systems.- use a symbolic representation and recognition is based on inferences.

Model based vision systems use predefined geometrical methods to recognize the objects whose description has been obtained from images, its principal components are: feature extraction, modelling, and matching and can use 2D or 3D

models. Because of its robustness and fast processing, manufacturing applications mostly use binary images, becoming the quantization process an important factor because all parametric calculations and description are derived from it. Shape based human recognition takes the information about perimeter as fundamental instead of regions, most 2D models used in real implementations are model and recognition object oriented as a function of its image representation as a 2D matrix array.

Knowledge based vision systems use proposal models for representation; they have a collection set of them representing knowledge about objects and their relationship. Recognition is achieved by way of inferences, from image data and domain knowledge, object identity is obtained, its principal components are:

- a) *feature extraction*, important attributes of the image are obtained to be integrated in a symbolic image
- b) *knowledge representation*, is constructed with a learning process being stored in the primitive knowledge data base
- c) *inference*, a deductive process is achieved from the symbolic image and primitive knowledge data base to get the object identity and location.

4. Visual behaviour

The problems of modelling and understanding visual behaviour and their semantics are often regarded as computationally ill-defined. Cognitive understanding cannot adequately explain why we associate particular meanings with observed behaviours. Interpretation of visual behaviour can rely on simple mappings from recognized patterns of motion to semantics, but human activity is complex, the same behaviour may have several different meanings depending upon the scene and task context. Behaviour interpretation often also requires real-time performance if it is to be correct in the relevant dynamic context, by real time, it is not necessary implied that all computation must be performed at full video frame-rate, as long as the interpretation of behaviour proceeds within some required time constraint, (Shaogang et. al., 2002).

Considering that it is estimated that 60% of sensory information in humans is provided by the visual pathway (Kronauer, 1985), and the biological vision

concerning the pathway is a massively parallel architecture using basic hierarchical information processing (Uhr, 1980), it seems logical to look for an alternative approach with less computational power to better emulate the human visual system and it is given by connectionist models of the human cognitive process, such idea has to be considered to develop machine vision system applications today, as robotic assembly vision guided manufacturing processes.

4.1 Inspiring Ideas

Sensorial capabilities are naturally used by humans and other life animals everyday; providing with sensorial capabilities to a machine is an interesting and actual challenge which means an open research area today. Figure 1, shows a baby grasping an object, even for him this is a natural way to achieve such a task with controlled movements and pointing to grasp targets by way of having real time visual information.



Figure 1. Human grasping action.

Visual information happens to be the 60% of the sensorial information coming in from human environment (Kronauer, 1985) and is mainly used for grasping objects; estimate his 3D position or assembly parts (figure 2).



Figure 2. Grasp, 3D position and assembly actions in humans.

The same action achieved by a robot machine implies different disciplines integration and a robust hardware and software implementation (figure 3).

Sensorial capabilities real time acquired information deals with different sensors, hardware architectures and communication and control approaches and configurations in order to achieve the task. Knowledge can be built either empirically or by hand as suggested by (Towell and Shavlik, 1994). Empirical knowledge can be thought of as giving examples on how to react to certain stimuli without any explanation and hand-built knowledge, where the knowledge is acquired by only giving explanations but without examples. It was determined that in robotic systems, a suitable strategy should include a combination of both methods. Furthermore, this idea is supported by psychological evidence that suggests that theory and examples interact closely during human learning, (Feldman, 1993).



Figure 3. Grasping action with a robot.

Learning in natural cognitive systems, including our own, follows a sequential process as it is demonstrated in our daily life. Events are learnt incrementally, for instance, during childhood when we start making new friends, we also learn more faces and this process continues through life. This learning is also stable because the learning of new faces does not disrupt our previous knowledge. These premises are the core for the development of *Connectionist Models of the Human Brain* and are supported by Psychology, Biology and Computer Sciences. Psychological studies suggest the sequential learning of events at different stages or “storage levels” termed as Sensory Memory (SM), Short Term Memory (STM) and Long Term Memory (LTM).

4.2 Artificial Neural Networks

There are different types of ANN, for this research a Fuzzy ARTMAP network is used, ART stands for Adaptive Resonance Theory, which is a well established associative brain and competitive model introduced as a theory of the human cognitive processing developed by Stephen Grossberg at Boston University. Grossberg resumed the situations mentioned above in what he called the *Stability-Plasticity Dilemma* suggesting that connectionist models should be able to adaptively switch between its plastic and stable modes. That is, a system should exhibit plasticity to accommodate new information regarding unfamiliar events. But also, it should remain in a stable condition if familiar or irrelevant information is being presented. These features suggested the use of this network because of its incremental knowledge capabilities and stability, but mostly because of the fast recognition and clustering responses.

Grossberg identified the problem as due to basic properties of associative learning and lateral inhibition. An analysis of this instability, together with data of categorisation, conditioning, and attention led to the introduction of the ART model that stabilises the memory of self-organising feature maps in response to an arbitrary stream of input patterns (S. Grossberg, 1976). The core principles of this theory and how Short Term Memory (STM) and Long Term Memory (LTM) interact during network processes of activation, associative learning and recall were published in the scientific literature back in the 60's.

The theory has evolved in a series of real-time architectures for unsupervised learning, the ART-1 algorithm for binary input patterns (G. Carpenter, 1987), supervised learning is also possible through ARTMAP (G. Carpenter, 1991), that uses two ART-1 modules that can be trained to learn the correspondence between input patterns and desired output classes. Different model variations have been developed to date based on the original ART-1 algorithm, ART-2, ART-2a, ART-3, Gaussian ART, EMAP, ViewNET, Fusion ARTMAP, LaminART just to mention but a few.

5. Manufacturing

5.1 Intelligent manufacturing systems

Different sensors have been used in manufacturing systems to achieve specific tasks such as robot guiding, soldering, sorting, quality control and inspection.

Integration of new architectures and methods using sensorial modalities in manufacturing cells like vision, force-sensing and voice recognition becomes an open research field today.

Most automated systems integrators and designers had pushed hard to get faster and more accurate industrial robot systems but sensorial capabilities have not been developed completely to provide the required flexibility and autonomy for manufacturing tasks.

Basic requirements within an industrial production environment have to be satisfied to guarantee an acceptable manufacturing process; some factors are the tool or work-piece position uncertainty, which is achieved by using expensive structured manufacturing cells. Other factors are the force-torque and interaction evaluation with the task environment. By using self-adaptive robots with sensorial capabilities and skill learning on-line, great flexibility and adaptability is given to manufactured processes, so the idea of giving machines capabilities like humans in learning and execution tasks becomes real, (L.Wu, 1996).

These ideas points to use in manufacturing applications today, what is called *Intelligent Manufacturing Systems*, and can be thought as a high technology set of tool devices arranged within a working close ambient called manufacturing cell, and having an efficient collective team work, to achieve an autonomous manufacturing process with on line reprogramming facilities and having a manufactured product as it output. Such an intelligent system then, becomes a self-adapting and self-learning system (figure 4).

5.2. Assembly

The success of assembly operations using industrial robots is currently based on the accuracy of the robot itself and the precise knowledge of the environment, i.e., information about the geometry of the assembly parts and their localisation in the workspace. Robot manipulators operate in real world situations with a high degree of uncertainty and require sensing systems to compensate from potential errors during operations. Uncertainties come from a wide variety of sources such as robot positioning errors, gear backlash, arm deflection, ageing of mechanisms and disturbances. Controlling all the above aspects would certainly be a very difficult task; therefore a simpler approach is preferred like using vision-guided robots for aligning parts in assembly tasks.

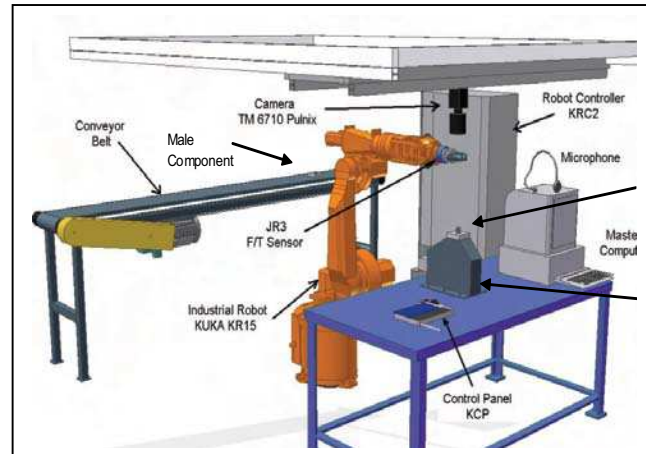

Figure 4. Intelligent Manufacturing System

6. Vision system

Machine Vision systems are mainly used today in applications as inspection, quality control and assembly tasks, they have been adopted now as a necessary technology in modern automated industries based in functional parameters and can be seen as a technology which is connecting cameras with computers for real-time interpretation of industrial behaviour images to acquire manufacturing applications. In this chapter a novel method to this purpose is presented and several tests were carried out to assess a vision-guided assembly process using aluminium pegs with different cross-sectional geometry, they are named: circular, squared and radiused-square (termed radiused-square because it was a square peg with one corner rounded). These components are shown in Figure 5 as well as the peg-in-hole operation in Figure 6. The diameter of the circular peg was 25 mm and the side of the square peg was also 25 mm. The dimensions of the non-symmetric part, the radiused-square, was the same as the squared peg with one corner rounded to a radius of 12.5 mm. Clearances between pegs and mating pairs were 0.1 mm, chamfers were at 45 degrees with 5 mm width. The assembly was ended when 3/4 of the body of the peg were inside the hole. This represented 140 motion steps in the -Z assembly direction.

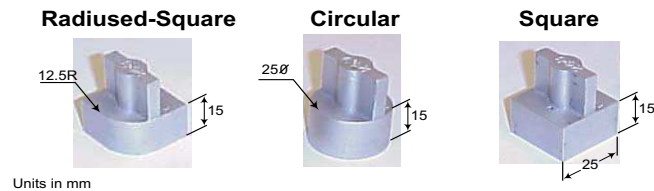

Figure 5. Assembly Components



Figure 6. Peg-in-hole operation

In our experiments, the robot grasps pieces from a conveyor belt and performs an assembly task using a force-sensing system described in (Corona-Castuera & Lopez-Juarez, 2006), the vision system obtains an image to recognize and calculates the object's pose estimation and sends the information to the robot.

6.1 Vision workspace

The vision system was implemented with a high speed camera CCD/B&W, PULNIX 6710, with 640x480 resolution and a PC dedicated computer, the

camera movements above the X-Y plane was implemented with a computer controlled 2D positioning electro-mechanical system (figure 7).



Figure 7. Vision workspace. Overview and 2D close up of positioning system

The vision system interaction schedule is working in a distributed systems as described in (Lopez-Juarez & Rios-Cabrera, 2006) linked to a robotic assembly module and a custom interface with a camera positioning system configured as a monocular dynamic system.

The vision system can get visual information from the manufacturing system workspace. To achieve an assembly task, the robotic assembly system sends commands to the vision system as follows:

\$SENDINF#1 Send Information of Zone 1:

zone 1 is the place where the robot grasps the male components. The robot can locate different pieces and their characteristics.

\$SENDINF#2 Send information of zone 2:

zone 2 is the place where the robot is performing the assembly task. The assembly system can request information about the female component such as position and shape.

\$RESEND#X Resend information of zone X:

This command will be useful when the information received by the assembly system coming from the vision system is incorrect, due to an error in the check sum or any other error.

The communication protocol is as follows:

# Zone	Command	Type	C-Sum
--------	---------	------	-------

The response from the vision system is a function of the request command from the assembly system, which coordinates the activities of the intelligent manufacturing cell (Corona-Castuera & Lopez-Juarez, 2004).

6.2 Invariant Object Recognition Methodology

The proposed methodology for invariant object recognition is based on the use of canonic shapes within what we have called the Primitive Knowledge Base (PKB). This PKB is conformed at training stage, once having embedded this knowledge, the idea is to improve and refine it on-line, which compares favourably with Gestalt principles such as grouping, proximity, similarity and simplicity. To illustrate the methodology, it will be useful to consider the assembly components used during experiments. The 2D representation of the working assembly pieces is shown in figure 8.

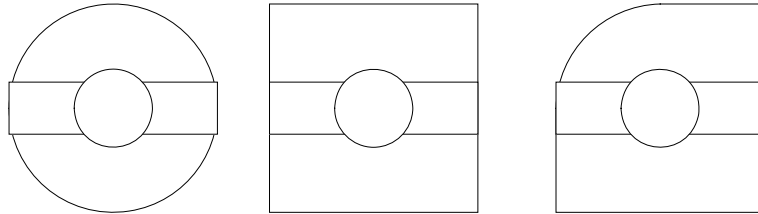

Figure 8. Assembly pieces

These canonical shapes serve as “clues” inserted initially in the PKB which initialise the grouping process (clustering). The knowledge is acquired by presenting multiple instances of the object such as those shown in figure 9 where an example of the circular shape and some of the possible views are illustrated. The following step is to code the object’s information to get a *descriptor vector*, so that its description be invariant to location, scaling and rotation, the algorithm is explained in the following section.

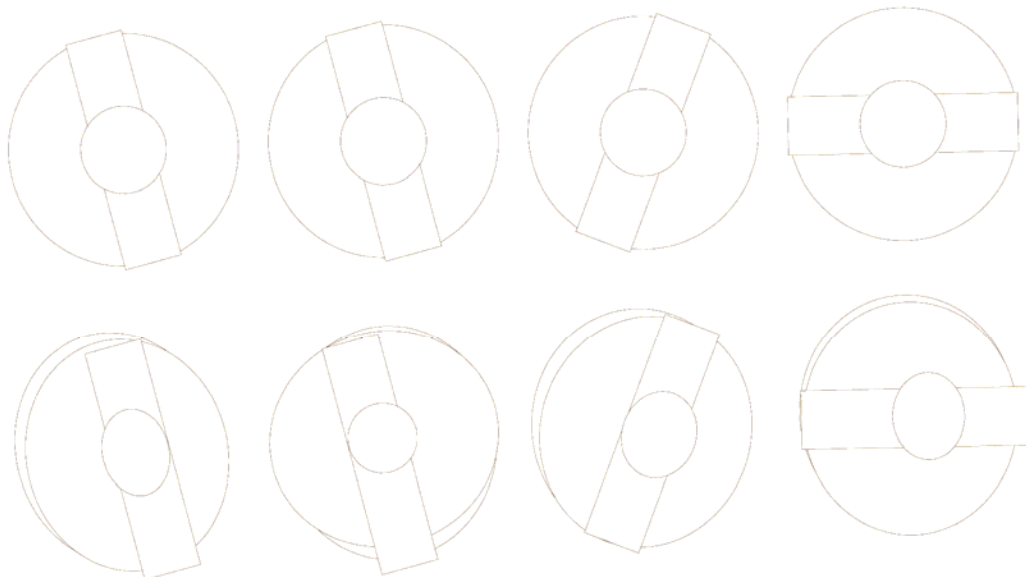

Figure 9. Multiple instances of the circular shape.

Having such a descriptor vector, an ANN can be trained to conform the *descriptor vector families* which can be generated on-line with the vision system.

Thank You for previewing this eBook

You can read the full version of this eBook in different formats:

- HTML (Free /Available to everyone)
- PDF / TXT (Available to V.I.P. members. Free Standard members can access up to 5 PDF/TXT eBooks per month each month)
- Epub & Mobipocket (Exclusive to V.I.P. members)

To download this full book, simply select the format you desire below

