

*Notes
for an Introductory Course
On Electrical Machines
and Drives*

E.G.Strangas

MSU Electrical Machines and Drives Laboratory

Contents

<i>Preface</i>	<i>ix</i>
1 <i>Three Phase Circuits and Power</i>	1
1.1 <i>Electric Power with steady state sinusoidal quantities</i>	1
1.2 <i>Solving 1-phase problems</i>	5
1.3 <i>Three-phase Balanced Systems</i>	6
1.4 <i>Calculations in three-phase systems</i>	9
2 <i>Magnetics</i>	15
2.1 <i>Introduction</i>	15
2.2 <i>The Governing Equations</i>	15
2.3 <i>Saturation and Hysteresis</i>	19
2.4 <i>Permanent Magnets</i>	21
2.5 <i>Faraday's Law</i>	22
2.6 <i>Eddy Currents and Eddy Current Losses</i>	25
2.7 <i>Torque and Force</i>	27
3 <i>Transformers</i>	29
3.1 <i>Description</i>	29
3.2 <i>The Ideal Transformer</i>	30
3.3 <i>Equivalent Circuit</i>	32
3.4 <i>Losses and Ratings</i>	36
3.5 <i>Per-unit System</i>	37

3.6	<i>Transformer tests</i>	40
3.6.1	<i>Open Circuit Test</i>	41
3.6.2	<i>Short Circuit Test</i>	41
3.7	<i>Three-phase Transformers</i>	43
3.8	<i>Autotransformers</i>	44
4	<i>Concepts of Electrical Machines; DC motors</i>	47
4.1	<i>Geometry, Fields, Voltages, and Currents</i>	47
5	<i>Three-phase Windings</i>	53
5.1	<i>Current Space Vectors</i>	53
5.2	<i>Stator Windings and Resulting Flux Density</i>	55
5.2.1	<i>Balanced, Symmetric Three-phase Currents</i>	58
5.3	<i>Phasors and space vectors</i>	58
5.4	<i>Magnetizing current, Flux and Voltage</i>	60
6	<i>Induction Machines</i>	63
6.1	<i>Description</i>	63
6.2	<i>Concept of Operation</i>	64
6.3	<i>Torque Development</i>	66
6.4	<i>Operation of the Induction Machine near Synchronous Speed</i>	67
6.5	<i>Leakage Inductances and their Effects</i>	71
6.6	<i>Operating characteristics</i>	72
6.7	<i>Starting of Induction Motors</i>	75
6.8	<i>Multiple pole pairs</i>	76
7	<i>Synchronous Machines and Drives</i>	81
7.1	<i>Design and Principle of Operation</i>	81
7.1.1	<i>Wound Rotor Carrying DC</i>	81
7.1.2	<i>Permanent Magnet Rotor</i>	82
7.2	<i>Equivalent Circuit</i>	82
7.3	<i>Operation of the Machine Connected to a Bus of Constant Voltage and Frequency</i>	84
7.4	<i>Operation from a Source of Variable Frequency and Voltage</i>	88
7.5	<i>Controllers for PMAC Machines</i>	94
7.6	<i>Brushless DC Machines</i>	95
8	<i>Line Controlled Rectifiers</i>	99
8.1	<i>1- and 3-Phase circuits with diodes</i>	99
8.2	<i>One -Phase Full Wave Rectifier</i>	100
8.3	<i>Three-phase Diode Rectifiers</i>	102
8.4	<i>Controlled rectifiers with Thyristors</i>	103

8.5	<i>One phase Controlled Rectifiers</i>	104
8.5.1	<i>Inverter Mode</i>	104
8.6	<i>Three-Phase Controlled Converters</i>	106
8.7	<i>*Notes</i>	107
9	<i>Inverters</i>	109
9.1	<i>1-phase Inverter</i>	109
9.2	<i>Three-phase Inverters</i>	111
10	<i>DC-DC Conversion</i>	117
10.1	<i>Step-Down or Buck Converters</i>	117
10.2	<i>Step-up or Boost Converter</i>	119
10.3	<i>Buck-boost Converter</i>	122

Preface

The purpose of these notes is to be used to introduce Electrical Engineering students to Electrical Machines, Power Electronics and Electrical Drives. They are primarily to serve our students at MSU: they come to the course on Energy Conversion and Power Electronics with a solid background in Electric Circuits and Electromagnetics, and many want to acquire a basic working knowledge of the material, but plan a career in a different area (venturing as far as computer or mechanical engineering). Other students are interested in continuing in the study of electrical machines and drives, power electronics or power systems, and plan to take further courses in the field.

Starting from basic concepts, the student is led to understand how force, torque, induced voltages and currents are developed in an electrical machine. Then models of the machines are developed, in terms of both simplified equations and of equivalent circuits, leading to the basic understanding of modern machines and drives. Power electronics are introduced, at the device and systems level, and electrical drives are discussed.

Equations are kept to a minimum, and in the examples only the basic equations are used to solve simple problems.

These notes do not aim to cover completely the subjects of Energy Conversion and Power Electronics, nor to be used as a reference, not even to be useful for an advanced course. They are meant only to be an aid for the instructor who is working with intelligent and interested students, who are taking their first (and perhaps their last) course on the subject. How successful this endeavor has been will be tested in the class and in practice.

In the present form this text is to be used solely for the purposes of teaching the introductory course on Energy Conversion and Power Electronics at MSU.

E.G.STRANGAS

E. Lansing, Michigan and Pyrgos, Tinos

A Note on Symbols

Throughout this text an attempt has been made to use symbols in a consistent way. Hence a script letter, say v denotes a scalar time varying quantity, in this case a voltage. Hence one can see

$$v = 5 \sin \omega t \text{ or } v = \hat{v} \sin \omega t$$

The same letter but capitalized denotes the rms value of the variable, assuming it is periodic. Hence:

$$v = \sqrt{2}V \sin \omega t$$

The capital letter, but now bold, denotes a phasor:

$$\mathbf{V} = V e^{j\theta}$$

Finally, the script letter, bold, denotes a space vector, i.e. a time dependent vector resulting from three time dependent scalars:

$$\mathbf{v} = v_1 + v_2 e^{j\gamma} + v_3 e^{j2\gamma}$$

In addition to voltages, currents, and other obvious symbols we have:

B	Magnetic flux Density (T)
H	Magnetic field intensity (A/m)
Φ	Flux (Wb) (with the problem that a capital letter is used to show a time dependent scalar)
$\lambda, \Lambda, \boldsymbol{\lambda}$	flux linkages (of a coil, rms, space vector)
ω_s	synchronous speed (in electrical degrees for machines with more than two-poles)
ω_o	rotor speed (in electrical degrees for machines with more than two-poles)
ω_m	rotor speed (mechanical speed no matter how many poles)
ω_r	angular frequency of the rotor currents and voltages (in electrical degrees)
T	Torque (Nm)
$\Re(\cdot), \Im(\cdot)$	Real and Imaginary part of \cdot

1

Three Phase Circuits and Power

Chapter Objectives

In this chapter you will learn the following:

- The concepts of power, (real reactive and apparent) and power factor
- The operation of three-phase systems and the characteristics of balanced loads in Y and in Δ
- How to solve problems for three-phase systems

1.1 ELECTRIC POWER WITH STEADY STATE SINUSOIDAL QUANTITIES

We start from the basic equation for the instantaneous electric power supplied to a load as shown in figure 1.1

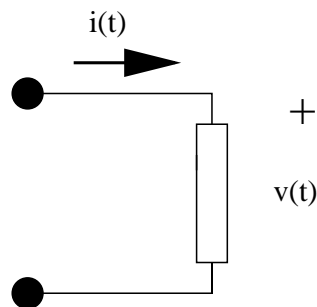

Fig. 1.1 A simple load

$$p(t) = i(t) \cdot v(t) \tag{1.1}$$

2 THREE PHASE CIRCUITS AND POWER

where $i(t)$ is the instantaneous value of current through the load and $v(t)$ is the instantaneous value of the voltage across it.

In quasi-steady state conditions, the current and voltage are both sinusoidal, with corresponding amplitudes \hat{i} and \hat{v} , and initial phases, ϕ_i and ϕ_v , and the same frequency, $\omega = 2\pi/T = 2\pi f$:

$$v(t) = \hat{v} \sin(\omega t + \phi_v) \quad (1.2)$$

$$i(t) = \hat{i} \sin(\omega t + \phi_i) \quad (1.3)$$

In this case the rms values of the voltage and current are:

$$V = \sqrt{\frac{1}{T} \int_0^T \hat{v} [\sin(\omega t + \phi_v)]^2 dt} = \frac{\hat{v}}{\sqrt{2}} \quad (1.4)$$

$$I = \sqrt{\frac{1}{T} \int_0^T \hat{i} [\sin(\omega t + \phi_i)]^2 dt} = \frac{\hat{i}}{\sqrt{2}} \quad (1.5)$$

and these two quantities can be described by phasors, $\mathbf{V} = V \angle \phi_v$ and $\mathbf{I} = I \angle \phi_i$.

Instantaneous power becomes in this case:

$$\begin{aligned} p(t) &= 2VI [\sin(\omega t + \phi_v) \sin(\omega t + \phi_i)] \\ &= 2VI \frac{1}{2} [\cos(\phi_v - \phi_i) + \cos(2\omega t + \phi_v + \phi_i)] \end{aligned} \quad (1.6)$$

The first part in the right hand side of equation 1.6 is independent of time, while the second part varies sinusoidally with twice the power frequency. The average power supplied to the load over an integer time of periods is the first part, since the second one averages to zero. We define as real power the first part:

$$P = VI \cos(\phi_v - \phi_i) \quad (1.7)$$

If we spend a moment looking at this, we see that this power is not only proportional to the rms voltage and current, but also to $\cos(\phi_v - \phi_i)$. The cosine of this angle we define as displacement factor, DF. At the same time, and in general terms (i.e. for periodic but not necessarily sinusoidal currents) we define as power factor the ratio:

$$pf = \frac{P}{VI} \quad (1.8)$$

and that becomes in our case (i.e. sinusoidal current and voltage):

$$pf = \cos(\phi_v - \phi_i) \quad (1.9)$$

Note that this is not generally the case for non-sinusoidal quantities. Figures 1.2 - 1.5 show the cases of power at different angles between voltage and current.

We call the power factor leading or lagging, depending on whether the current of the load leads or lags the voltage across it. It is clear then that for an inductive/resistive load the power factor is lagging, while for a capacitive/resistive load the power factor is leading. Also for a purely inductive or capacitive load the power factor is 0, while for a resistive load it is 1.

We define the product of the rms values of voltage and current at a load as apparent power, S :

$$S = VI \quad (1.10)$$

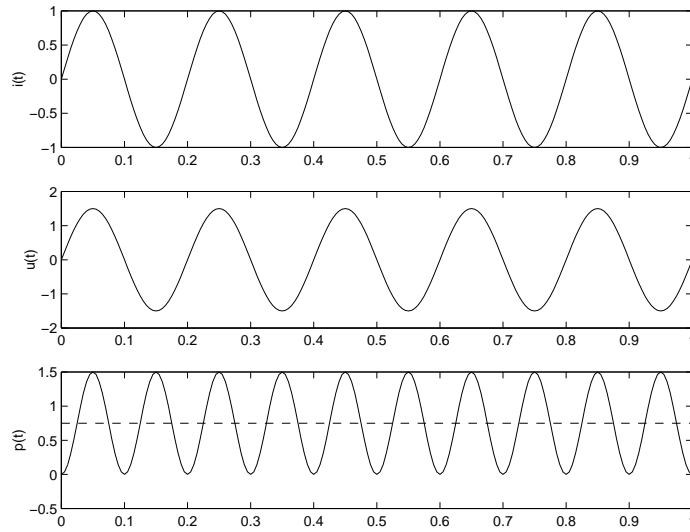

Fig. 1.2 Power at pf angle of 0° . The dashed line shows average power, in this case maximum

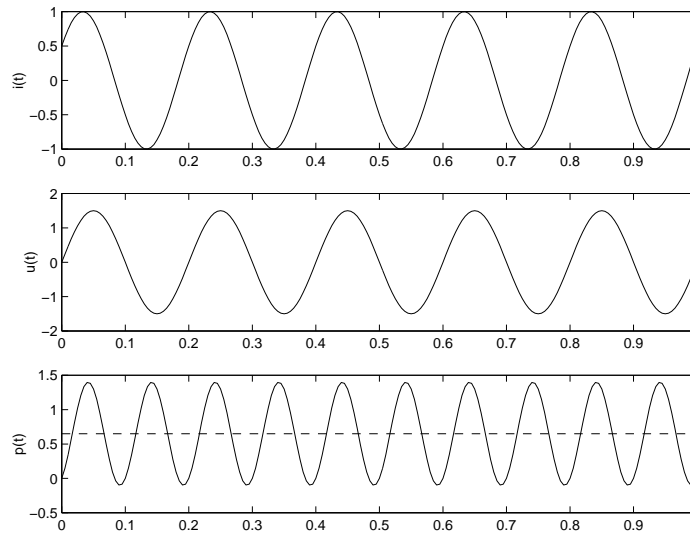

Fig. 1.3 Power at pf angle of 30° . The dashed line shows average power

and as reactive power, Q

$$Q = VI \sin(\phi_v - \phi_i) \quad (1.11)$$

Reactive power carries more significance than just a mathematical expression. It represents the energy oscillating in and out of an inductor or a capacitor and a source for this energy must exist. Since the energy oscillation in an inductor is 180° out of phase of the energy oscillating in a capacitor,

4 THREE PHASE CIRCUITS AND POWER

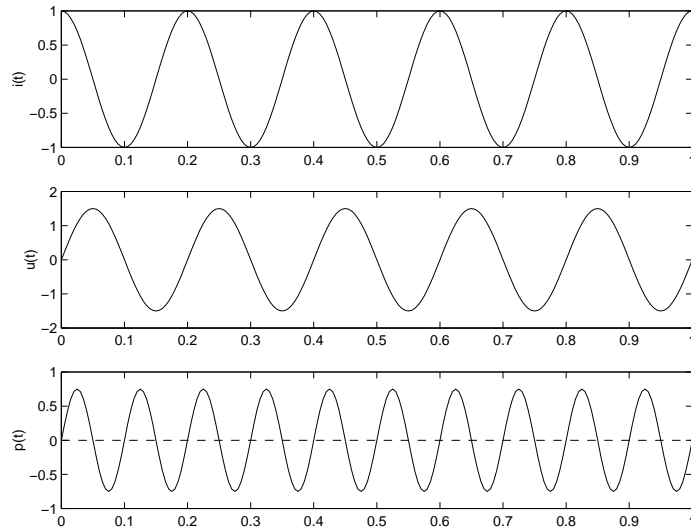

Fig. 1.4 Power at pf angle of 90° . The dashed line shows average power, in this case zero

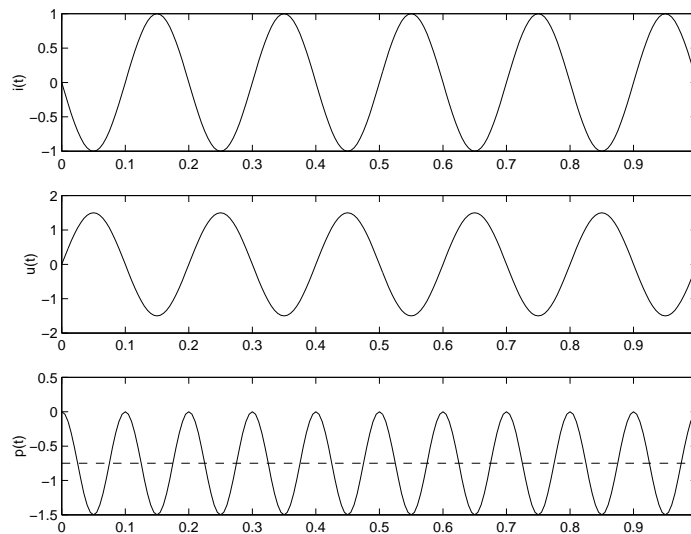

Fig. 1.5 Power at pf angle of 180° . The dashed line shows average power, in this case negative, the opposite of that in figure 1.2

the reactive power of the two have opposite signs by convention positive for an inductor, negative for a capacitor.

The units for real power are, of course, W , for the apparent power VA and for the reactive power Var .

Using phasors for the current and voltage allows us to define complex power \mathbf{S} as:

$$\mathbf{S} = \mathbf{VI}^* \tag{1.12}$$

$$= V \angle \phi_v I \angle -\phi_i \tag{1.13}$$

and finally

$$\mathbf{S} = P + jQ \tag{1.14}$$

For example, when

$$v(t) = \sqrt{2} \cdot 120 \cdot \sin(377t + \frac{\pi}{6})V \tag{1.15}$$

$$i(t) = \sqrt{2} \cdot 5 \cdot \sin(377t + \frac{\pi}{4})A \tag{1.16}$$

then $S = VI = 120 \cdot 5 = 600W$, while $pf = \cos(\pi/6 - \pi/4) = 0.966$ leading. Also:

$$\mathbf{S} = \mathbf{VI}^* = 120 \angle \pi/6 \cdot 5 \angle -\pi/4 = 579.6W - j155.3VAr \tag{1.17}$$

Figure 1.6 shows the phasors for lagging and leading power factors and the corresponding complex power \mathbf{S} .

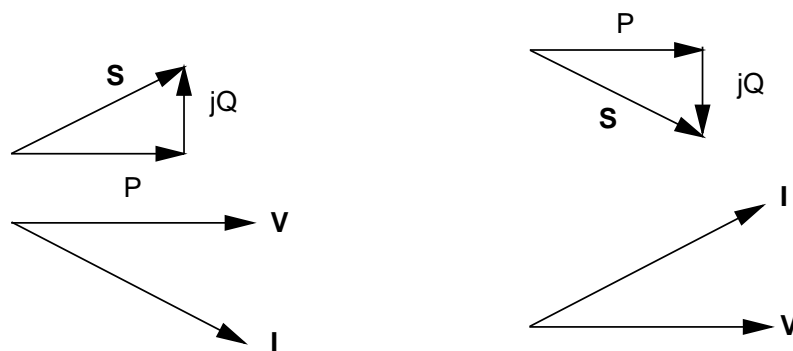

Fig. 1.6 (a) lagging and (b) leading power factor

1.2 SOLVING 1-PHASE PROBLEMS

Based on the discussion earlier we can construct the table below:

Type of load	Reactive power	Power factor
Reactive	$Q > 0$	lagging
Capacitive	$Q < 0$	leading
Resistive	$Q = 0$	1

6 THREE PHASE CIRCUITS AND POWER

We also notice that if for a load we know any two of the four quantities, S , P , Q , pf , we can calculate the other two, e.g. if $S = 100kVA$, $pf = 0.8$ leading, then:

$$\begin{aligned} P &= S \cdot pf = 80kW \\ Q &= -S\sqrt{1 - pf^2} = -60kVAr, \text{ or} \\ \sin(\phi_v - \phi_i) &= \sin[\arccos 0.8] \\ Q &= S \sin(\phi_v - \phi_i) \end{aligned}$$

Notice that here $Q < 0$, since the pf is leading, i.e. the load is capacitive.

Generally in a system with more than one loads (or sources) real and reactive power balance, but *not* apparent power, i.e. $P_{total} = \sum_i P_i$, $Q_{total} = \sum_i Q_i$, but $S_{total} \neq \sum_i S_i$.

In the same case, if the load voltage were $V_L = 2000V$, the load current would be $I_L = S/V = 100 \cdot 10^3 / 2 \cdot 10^3 = 50A$. If we use this voltage as reference, then:

$$\begin{aligned} \mathbf{V} &= 2000 \angle 0^\circ V \\ \mathbf{I} &= 50 \angle \phi_i = 50 \angle 36.9^\circ A \\ \mathbf{S} &= \mathbf{V} \mathbf{I}^* = 2000 \angle 0^\circ \cdot 50 \angle -36.9^\circ = P + jQ = 80 \cdot 10^3 W - j60 \cdot 10^3 VAr \end{aligned}$$

1.3 THREE-PHASE BALANCED SYSTEMS

Compared to single phase systems, three-phase systems offer definite advantages: for the same power and voltage there is less copper in the windings, and the total power absorbed remains constant rather than oscillate around its average value.

Let us take now three sinusoidal-current sources that have the same amplitude and frequency, but their phase angles differ by 120° . They are:

$$\begin{aligned} i_1(t) &= \sqrt{2}I \sin(\omega t + \phi) \\ i_2(t) &= \sqrt{2}I \sin(\omega t + \phi - \frac{2\pi}{3}) \\ i_3(t) &= \sqrt{2}I \sin(\omega t + \phi + \frac{2\pi}{3}) \end{aligned} \quad (1.18)$$

If these three current sources are connected as shown in figure 1.7, the current returning through node n is zero, since:

$$\sin(\omega t + \phi) + \sin(\omega t - \phi + \frac{2\pi}{3}) + \sin(\omega t + \phi + \frac{2\pi}{3}) \equiv 0 \quad (1.19)$$

Let us also take three voltage sources:

$$\begin{aligned} v_a(t) &= \sqrt{2}V \sin(\omega t + \phi) \\ v_b(t) &= \sqrt{2}V \sin(\omega t + \phi - \frac{2\pi}{3}) \\ v_c(t) &= \sqrt{2}V \sin(\omega t + \phi + \frac{2\pi}{3}) \end{aligned} \quad (1.20)$$

connected as shown in figure 1.8. If the three impedances at the load are equal, then it is easy to prove that the current in the branch $n - n'$ is zero as well. Here we have a first reason why

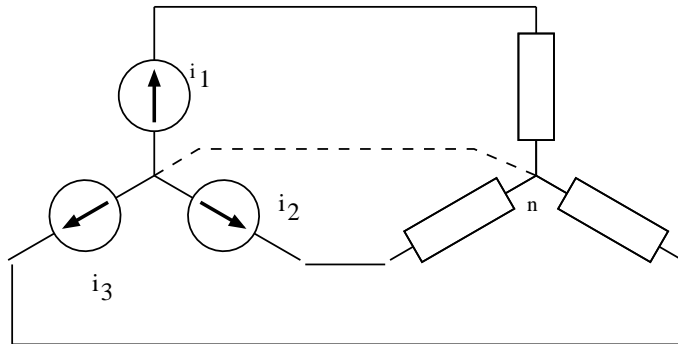

Fig. 1.7 Zero neutral current in a Y-connected balanced system

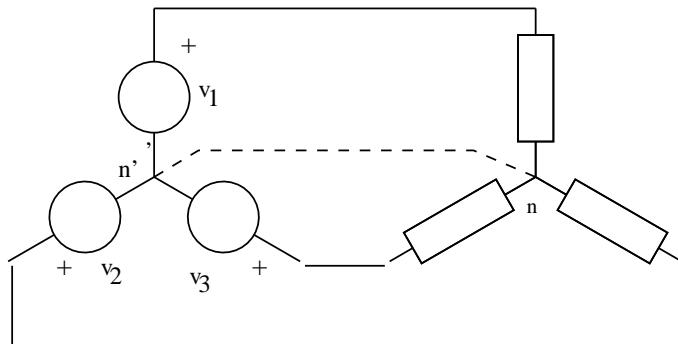

Fig. 1.8 Zero neutral current in a voltage-fed, Y-connected, balanced system.

three-phase systems are convenient to use. The three sources together supply three times the power that one source supplies, but they use three wires, while the one source alone uses two. The wires of the three-phase system and the one-phase source carry the same current, hence with a three-phase system the transmitted power can be tripled, while the amount of wires is only increased by 50%.

The loads of the system as shown in figure 1.9 are said to be in Y or star. If the loads are connected as shown in figure 1.11, then they are said to be connected in Delta, Δ , or triangle. For somebody who cannot see beyond the terminals of a Y or a Δ load, but can only measure currents and voltages there, it is impossible to discern the type of connection of the load. We can therefore consider the two systems equivalent, and we can easily transform one to the other without any effect outside the load. Then the impedances of a Y and its equivalent Δ symmetric loads are related by:

$$Z_Y = \frac{1}{3}Z_\Delta \tag{1.21}$$

Let us take now a balanced system connected in Y, as shown in figure 1.9. The voltages between the neutral and each of the three phase terminals are $V_{1n} = V \angle \phi$, $V_{2n} = V \angle \phi - \frac{2\pi}{3}$, and $V_{3n} = V \angle \phi + \frac{2\pi}{3}$. Then the voltage between phases 1 and 2 can be shown either through trigonometry or vector geometry to be:

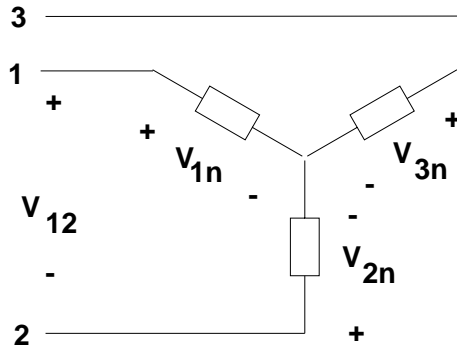

Fig. 1.9 Y Connected Loads: Voltages and Currents

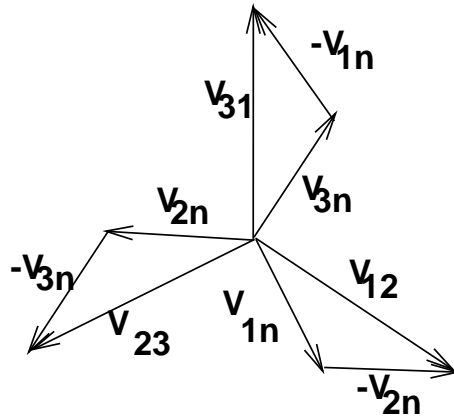

Fig. 1.10 Y Connected Loads: Voltage phasors

$$V_{12} = V_1 - V_2 = \sqrt{3}V \angle \phi + \frac{\pi}{3} \quad (1.22)$$

This is shown in the phasor diagrams of figure 1.10, and it says that the rms value of the line-to-line voltage at a Y load, V_{ll} , is $\sqrt{3}$ times that of the line-to-neutral or phase voltage, V_{ln} . It is obvious that the phase current is equal to the line current in the Y connection. The power supplied to the system is three times the power supplied to each phase, since the voltage and current amplitudes and the phase differences between them are the same in all three phases. If the power factor in one phase is $pf = \cos(\phi_v - \phi_i)$, then the total power to the system is:

$$\begin{aligned} S_{3\phi} &= P_{3\phi} + jQ_{3\phi} \\ &= 3V_1 I_1^* \\ &= \sqrt{3}V_{ll} I_l \cos(\phi_v - \phi_i) + j\sqrt{3}V_{ll} I_l \sin(\phi_v - \phi_i) \end{aligned} \quad (1.23)$$

Similarly, for a connection in Δ , the phase voltage is equal to the line voltage. On the other hand, if the phase currents phasors are $I_{12} = I \angle \phi$, $I_{23} = I \angle \phi - \frac{2\pi}{3}$ and $I_{31} = I \angle \phi + \frac{2\pi}{3}$, then the current of

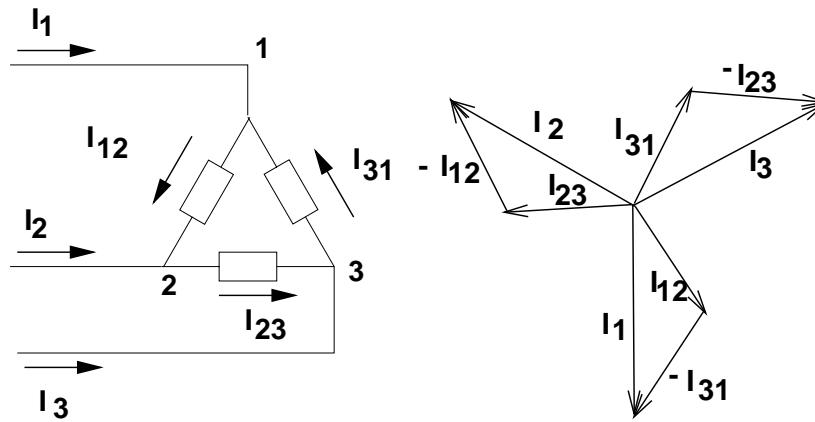

Fig. 1.11 Δ Connected Loads: Voltages and Currents

line 1, as shown in figure 1.11 is:

$$\mathbf{I}_1 = \mathbf{I}_{12} - \mathbf{I}_{31} = \sqrt{3}I \angle \phi - \frac{\pi}{3} \quad (1.24)$$

To calculate the power in the three-phase, Y connected load,

$$\begin{aligned} \mathbf{S}_{3\phi} &= P_{3\phi} + jQ_{3\phi} \\ &= 3\mathbf{V}_1 \mathbf{I}_1^* \\ &= \sqrt{3}V_{ll} I_l \cos(\phi_v - \phi_i) + j\sqrt{3}V_{ll} I_l \sin(\phi_v - \phi_i) \end{aligned} \quad (1.25)$$

1.4 CALCULATIONS IN THREE-PHASE SYSTEMS

It is often the case that calculations have to be made of quantities like currents, voltages, and power, in a three-phase system. We can simplify these calculations if we follow the procedure below:

1. transform the Δ circuits to Y ,
2. connect a neutral conductor,
3. solve one of the three 1-phase systems,
4. convert the results back to the Δ systems.

1.4.1 Example

For the 3-phase system in figure 1.12 calculate the line-line voltage, real power and power factor at the load.

First deal with only one phase as in the figure 1.13:

$$\begin{aligned} \mathbf{I} &= \frac{120}{j1 + 7 + j5} = 13.02 \angle -40.6^\circ \text{ A} \\ \mathbf{V}_{ln} &= \mathbf{I} \mathbf{Z}_1 = 13.02 \angle -40.6^\circ (7 + j5) = 111.97 \angle -5^\circ \text{ V} \\ \mathbf{S}_{L,1\phi} &= \mathbf{V}_L \mathbf{I}^* = 1.186 \cdot 10^3 + j0.847 \cdot 10^3 \\ P_{L1\phi} &= 1.186 \text{ kW}, \quad Q_{L1\phi} = 0.847 \text{ kVar} \\ pf &= \cos(-5^\circ - (-40.6^\circ)) = 0.814 \text{ lagging} \end{aligned}$$

Thank You for previewing this eBook

You can read the full version of this eBook in different formats:

- HTML (Free /Available to everyone)
- PDF / TXT (Available to V.I.P. members. Free Standard members can access up to 5 PDF/TXT eBooks per month each month)
- Epub & Mobipocket (Exclusive to V.I.P. members)

To download this full book, simply select the format you desire below

